

# 3

## IS-136 TDMA Technology

**T**HE IS-136 STANDARD is the basis of the TDMA cellular and personal communications services (PCS) air interface technology. IS-136 systems allow telecommunications companies to offer advanced features and services to subscribers while maintaining backward compatibility for their existing customer bases. It also provides a cost-effective migration path from AMPS and earlier TDMA systems through the use of dual-mode operation—where analog or digital capabilities can be used according to system resources and phone capability.

The DCCH forms the core of the IS-136 specification. It is the primary enhancement to IS-54B (ANSI standard TIA/EIA 627) technology and represents the next generation of TDMA-based digital operation. The analog portion of the AMPS EIA-553 specification was incorporated into the new digital specification to provide a smooth migration path and to continue the analog and digital dual mode philosophy.

The IS-136 DCCH makes TDMA a powerful PCS technology since it provides a platform for advanced features and services and is designed to work seamlessly on either the 800-MHz or 1,900-MHz frequency.

The IS-136 specification is actually two documents containing the specification information necessary for development of IS-136-based products. Figure 3.1 shows the evolution of the digital cellular system specification.

## 3.1 Technology requirements

### 3.1.1 New features

IS-136 introduces the DCCH, which provides new system functionality and supports enhanced features including the following.

- A battery life power saving process called sleep mode;
- Support for multiple vocoders to take advantage of new voice improvement technology;
- The ability to seamlessly acquire the same services in either the cellular (800-MHz) or so-called PCS (1,900 MHz) frequency band;
- A teleservice feature for transferring application data to and from cellular phones—including the *cellular messaging teleservice* (CMT),

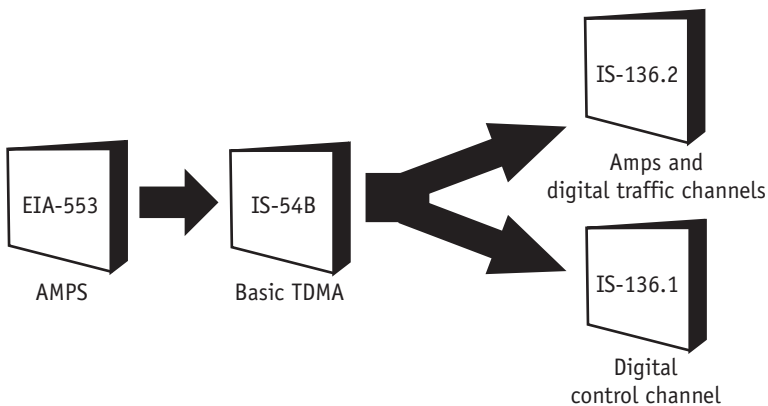

**Figure 3.1** Evolution of the IS-136 specification.

which delivers short alphanumeric messages to the phone, and the *over-the-air activation* (OAA) *teleservice* (OATS), which allows for delivery of provisioning information to the phone;

- A hierarchical macrocell-microcell environment providing support for microcellular operation;
- Private and residential system identities providing the tools for *wireless office service* (WOS) operation;
- The ability to quickly roll out advanced services to meet future consumer needs.

These features are discussed fully in Chapter 10.

The *Cellular Telephone Industry Association* (CTIA) commissioned the creation of a *user performance requirements document* (UPR) in 1989. The basic requirements of the UPR, which are supported in the IS-136 environment, include increased capacity, new features, equipment availability, voice quality, and backward compatibility.

### 3.1.2 Increased capacity

It appeared that cellular systems were running into a capacity limit in the early 1990s. In some urban areas, cell sites were approaching a 1/2-mile radius, which was considered the minimum practical cell size for an AMPS system. This meant that cellular carriers were concerned that there was a fundamental limit on the maximum number of customers that they could serve in a given geographical area. Serving more customers simultaneously with the same amount of radio spectrum was considered essential to continued growth and survival.

There were two capacity issues: voice channel capacity and control channel capacity. Voice channel capacity was increased by dividing the radio channel into time slots, and control channel capacity was increased by adding a DCCH.

### 3.1.3 New features

To better serve their customers, cellular carriers specified new features such as short messaging, extended battery life, and data services. A

priority list was created for key features (such as calling number identification) and low priority features (such as video service).

#### **3.1.4 Equipment availability**

The cellular carriers wanted to have digital mobile phones available quickly, to increase capacity, and to allow for advanced features. Since digital-only service was not expected to be available throughout the entire United States for several years, digital equipment was expected to be dual-mode, or capable of operating on both the AMPS and digital system, where appropriate.

#### **3.1.5 Voice quality**

Cellular carriers aim to provide voice quality comparable to that supplied by wired telephones. Due to the robust nature of digital communications, digital voice service has, in many cases, voice quality superior to that of AMPS analog technology.

#### **3.1.6 Compatibility with AMPS and IS-54B systems**

A primary consideration in early plans for the DCCH and the introduction of its features was the ability to implement the technology quickly and to minimize disruption in the existing cellular system. To achieve this, many of the first generation TDMA (IS-54B) physical radio characteristics are retained in IS-136. For example, in addition to retaining the TDMA slot and frame structure, the IS-54B in-call messaging remains the same in the IS-136 environment. Table 3.1 lists the compatibility and transmission requirements addressed during development of the IS-136 standard.

### **3.2 IS-136 radio technology**

The radio technology used in the IS-136 system provides a channel for advanced services and improved system efficiency through the use of voice digitization, speech compression (coding), channel coding, efficient radio modulation, enhanced RF power control, and a flexible approach to spectrum usage.

**Table 3.1**  
Key System Development Requirements

Requirement	Benefit
Allow a new control channel (DCCH) to coexist with the current TDMA cellular channels	Multiple number of control channels per base station can exist
Maintain the same type of modulation as IS-54B	No significant system hardware changes would be required
Maintain the IS-54B basic call processing process	Simplified equipment design to perform on IS-136 system
Make only minimal changes to the DTC	IS-54B phones will not be confused with advanced features when they operate in the IS-136 system
Keep the same set of channel coding (error protection) types for the DCCH and the DTC	Simplified signal processing reduces complexity and power consumption
Capability to mix a DTC and a DCCH on any frequency	Allows a flexible use of the radio spectrum

### 3.2.1 Voice digitization

The first step in a digital cellular system is the conversion of an acoustic voice signal into a digital signal. As the customer speaks into the microphone, an analog audio signal is created. The audio signal is very complex and contains very high and low frequencies that are not necessary for communication. A filter is, therefore, used to remove any signals below 100 Hz or above 3,000 Hz before further processing. The filtered audio signal is then converted to a digital value at a sampling rate of 8,000 times per second. For each sample, an eight-bit digital value is created. The resulting 64,000-bps digital signal represents the voice information.

### 3.2.2 Speech data compression

After the voice digitization process, the digitized audio signal is typically 64 Kbps. To efficiently send a digitized voice signal, the IS-136 uses speech data compression. This is performed by a speech coder. The speech coder characterizes the digitized audio signal and attempts to

ignore patterns that are not characteristic of the human voice. The result is a digital signal that represents the voice content. When this compressed speech information is received, a speech decoder is used to recreate the original signal.

The IS-136 speech coder analyzes the 64 Kbps speech information and characterizes it by pitch, volume, and other parameters. Figure 3.2 illustrates the speech compression process. As the speech coder characterizes the input signal, it looks up information in a code book table and selects the code that most accurately represents the input signal. For the IS-136 TDMA system, the compression is 8:1.

As speech data compression technologies have developed, improved speech coders have become available. Hence, IS-136 can use either the original IS-54B *vector sum excited linear predictive* (VSELP) speech coder or the IS-641 *enhanced full rate* (EFR) *algebraic code excited linear predictive* (ACELP) speech coder. The EFR codec provides voice quality comparable to the landline reference *adaptive differential pulse coded modulation* (ADPCM) under normal radio channel conditions. Additionally, the EFR errored channel performance results in significant voice quality improvements.

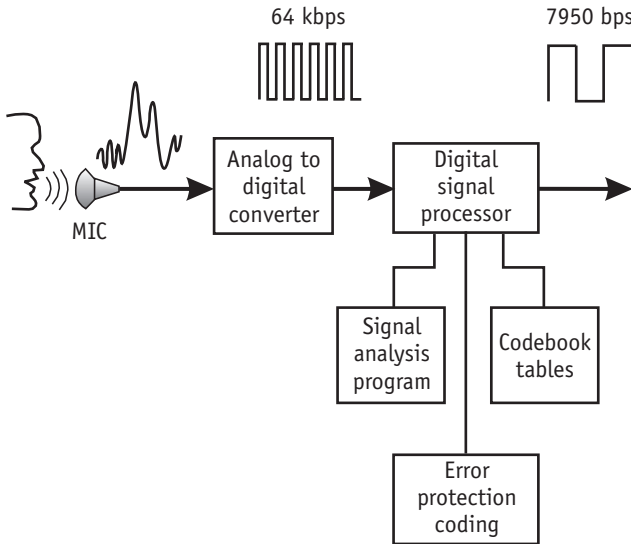

**Figure 3.2** Speech coding.

### 3.2.3 Channel coding

After the digital speech information is compressed, control information bits are added along with error protection bits. Control messages are either time-multiplexed (simultaneously sent), or they replace (blank and burst) the speech information. Error protection bits offer a way to detect errors and to correct some errors that are introduced during radio transmission. Error protection for the IS-136 system consists of block coding and convolutional (continuous) coding. Block coding adds bits to the end of a frame (usually after several hundred bits) of information. These bits allow the receiver to determine if all the information has been received correctly or whether information should be retransmitted.

Convolutional coding involves creating unique data bits that represent the original data information combined with an error protection coding process. This information is sent simultaneously with the actual data to be transmitted. Convolutional coders are described by the relationship between the number of bits entering and leaving the coder. For example, a  $1/2$ -rate convolutional coder generates two bits for every one that enters. The larger the relationship, the more redundancy and the better the error protection. A  $1/4$ -rate convolutional coder has much more error protection capability than a  $1/2$ -rate coder.

### 3.2.4 Modulation

The IS-136 digital radio channel uses phase modulation. Phase modulation is a process that converts digital bits into phase shifts in the radio signal. Phase modulation is a result of shifting the carrier frequency higher and lower to introduce phase changes at specific points in time.

The IS-136 digital channels use  $\pi/4$  DQPSK modulation.  $\pi/4$  DQPSK modulation was chosen to maintain spectral efficiency and to optimize the RF amplifier section. To create a  $\pi/4$  QPSK modulated signal, typically two amplitude-modulated RF signals that are 90 degrees out of phase are combined. The digital information is represented by the signals' amplitudes; the resulting signal is at the same frequency and shifted in phase. This phenomenon allows the transfer of information, since different bit patterns input to the modulator cause specific amounts of phase shift in the output transmission. Therefore, if the received RF signal is sampled for phase transitions and amplitude at

specific periods of time, it is possible to recreate the original bit pattern. The four allowed phase shifts (+45, +135, -45, and -135 degrees) represent the original binary information. The receiver looks for anticipated phase information, called a decision point.

Each two-bit stimulus input has a corresponding phase shift. The transition period between decision points is 41.15  $\mu$ sec, resulting in a symbol rate of 24.3 thousand symbols per second (Ksps). Each symbol represents 2 bits, so the input data rate is 48.6 Kbps.

Digital modulation results in RF power that is distributed over a wider frequency bandwidth than AMPS FM modulation. This has resulted in a more tolerant requirement for this RF spectral density (covered in Chapter 6) than for AMPS channels. The requirement for this spectral mask was derived from adjacent channel and cochannel interference levels.

### **3.2.5 RF power**

A major difference between digital and analog technologies is that digital requires a linear RF amplifier. A linear amplifier distorts the signal less than the class C RF amplifiers used in AMPS cellular telephones. Unfortunately, the battery-to-RF energy conversion efficiency for linear amplifiers is 30–40% compared with 40–55% for class C RF amplifiers used in AMPS phones. Linear amplifiers require more input energy to produce the same RF energy output power during transmission. Digital technologies overcome this limitation either by transmitting for shorter periods or by precisely controlling power to transmit at lower average output power.

The IS-136 system adds a new power class of mobile phone. The class IV mobile phone output power is identical to class III, but its minimum power is 12 dB lower. The lower minimum power allows systems to reduce the minimum cell site radius. Table 3.2 shows the power classification types for the IS-54B radio system.

### **3.2.6 Frequency allocation**

IS-136 uses the existing cellular radio channels in the 850-MHz band as well as the radio channels at 1,900 MHz. In either band, the channels are

**Table 3.2**  
IS-136 Power Classification

RF Power	Class I	Class II	Class III	Class IV	Class V-VI
Maximum power	4W	1.6W	.6W	.6W	Reserved
Average power (full rate TDMA)	1.333W	.533W	.2W	.2W	Reserved
Minimum power	6 mW	6 mW	6 mW	0.5 mW	Reserved

30-kHz wide. Figure 3.3 displays the IS-136 frequency allocation. Note that EIA 553 *analog control channels* (ACCs) and analog voice channels are

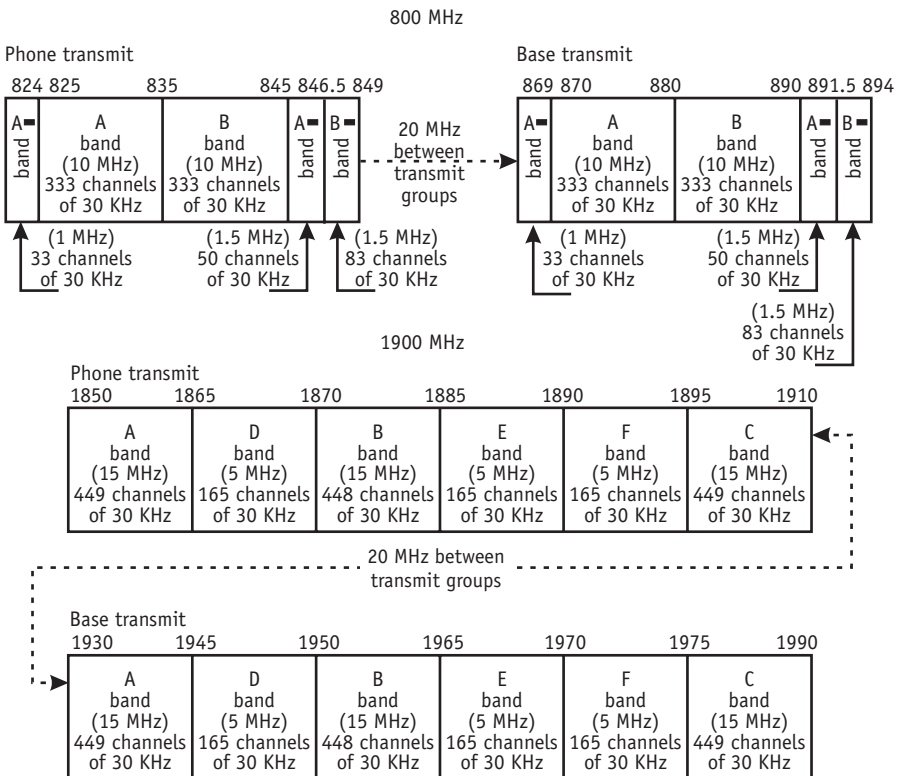

**Figure 3.3** The 800-MHz and 1,900-MHz spectrum.

only available at 800 MHz. TDMA digital traffic and DCCCHs are, however, available at both 800 and 1,900 MHz for seamless access to new features.

To calculate the frequency of the cellular radio channel, the following formulas, in which  $N$  represents the channel number, are used:

- For the 800-MHz band reverse channel:

$$1 \text{ to } 799: 0.03(N) + 825 \text{ MHz};$$

$$990 \text{ to } 1023: 0.03(N - 1023) + 825 \text{ MHz}.$$

- For the 800-MHz band forward channel:

$$1 \text{ to } 799: 0.03(N) + 870 \text{ MHz};$$

$$990 \text{ to } 1023: 0.03(N - 1023) + 870 \text{ MHz}.$$

To calculate the frequency of the PCS radio channel, the following formulas, where  $N$  is the channel number, are used:

- For the 1,900-MHz band reverse channel:

$$1 \text{ to } 1999: 0.03(N) + 1849.980 \text{ MHz}.$$

- For the 1,900 MHz band forward channel:

$$1 \text{ to } 1999: 0.03(N) + 1930.020 \text{ MHz}.$$

### 3.3 The digital traffic channel environment

30 kHz radio channels are divided up to support many digital users in the same bandwidth as one analog user. This requires a new radio channel structure in addition to new modulation and signaling.

#### 3.3.1 Radio channel structure

The digital channel is frequency-duplex, meaning that the transmit and receive operations take place on different frequencies. These receive and transmit frequencies are divided into time slots that also allow *time division duplex* (TDD) operation. Forward and reverse channels are separated by 45 MHz in the 800-MHz band and by

80.04 MHz in the 1,900-MHz band. The transmit band for the 800-MHz base station is 869–894 MHz and 1,930–1,990 MHz for the 1,900-MHz base station. The mobile transmit frequency is 824–849 MHz for the 800-MHz band and 1,850–1,910 MHz for the 1,900-MHz band. The same 30-kHz channel bandwidth is the same for AMPS and IS-136 *digital traffic channels* (DTCs). Figure 3.4 shows the IS-136 radio channel structure.

To prevent a mobile phone's receive and transmit messages from interfering with each other, IS-136 systems separate transmit and receive frequencies and separate transmission and reception in time. The time separation or offset simplifies the design of transmitters and receivers. Figure 3.5 shows IS-136 system time and frequency separations between receive and transmit channels.

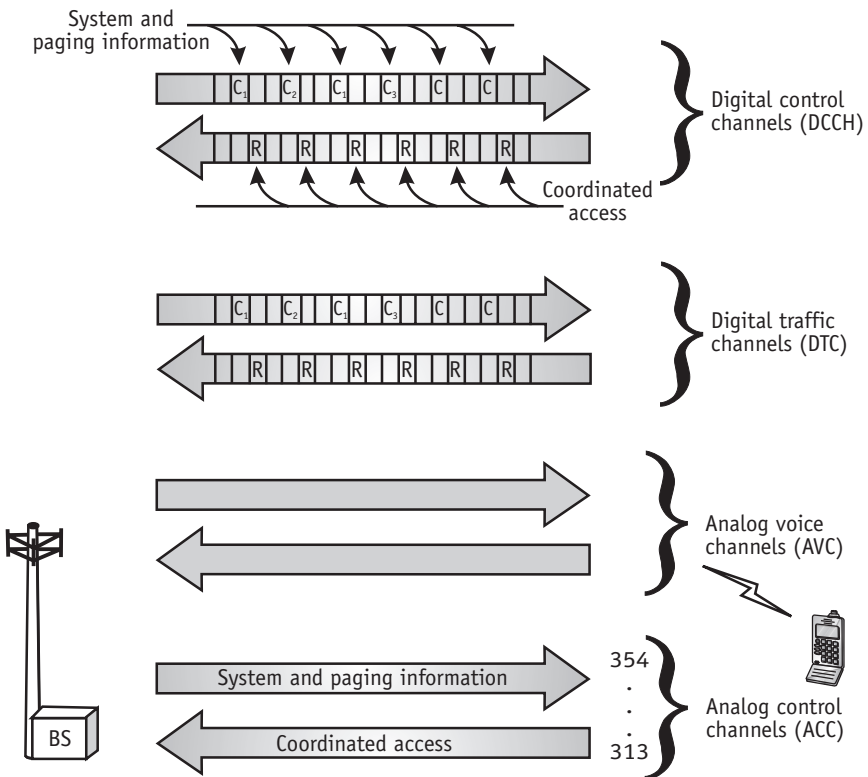

**Figure 3.4** IS-136 radio channel structure.

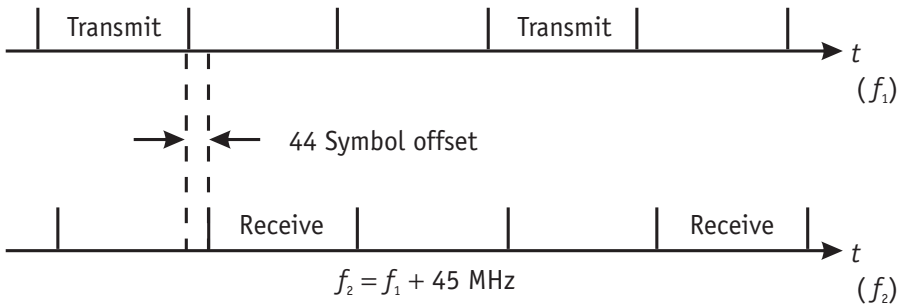

**Figure 3.5** IS-136 radio channel time offset.

There are two types of channel usage available in an IS-136 system: Full-rate IS-136 systems allow three users to simultaneously share a radio channel. Half-rate IS-136 systems allow six users to share a radio channel. Other channel usage consisting of double and triple rate channels will be available for data users in the future.

### 3.3.1.1 Full-rate TDMA

For the full-rate IS-136 radio channel, two time slots are used for transmitting, two are used for receiving, and two are idle. The mobile phone typically uses the idle time to measure the signal strength of surrounding channels to assist in hand-off. Mobile phones transmit every third slot so that phone #1 uses slots 1 and 4, phone #2 uses slots 2 and 5, while phone #3 uses slots 3 and 6. This time sharing results in a user-available data rate of 13 Kbps. However, some of the user data is used for error detection and correction, leaving 8 Kbps of data available for compressed speech data. Figure 3.6 shows how TDMA full-duplex radio channels are divided in time to serve up to three customers per channel.

### 3.3.1.2 Half-rate TDMA

A radio channel's capacity can be doubled by dedicating only one slot per frame per customer, creating a half-rate channel. Half-rate channels use one of the six slots to transmit and one to receive, leaving four idle. In this case, a half-rate vocoder operating at 4 Kbps would be required to take advantage of the smaller bandwidth allocation. Figure 3.7 illustrates the half-rate TDMA channel structure.

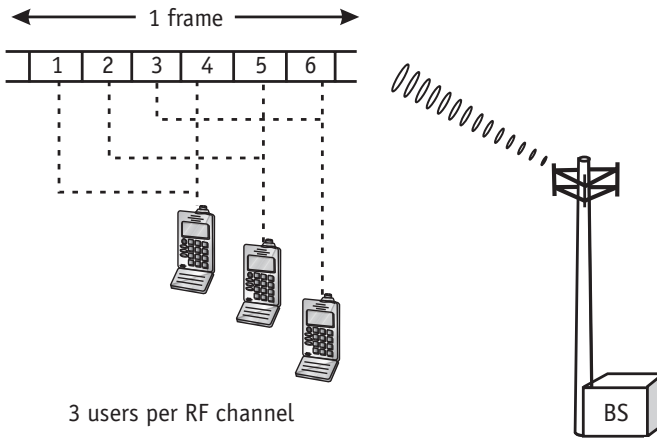

**Figure 3.6** IS-136 full rate.

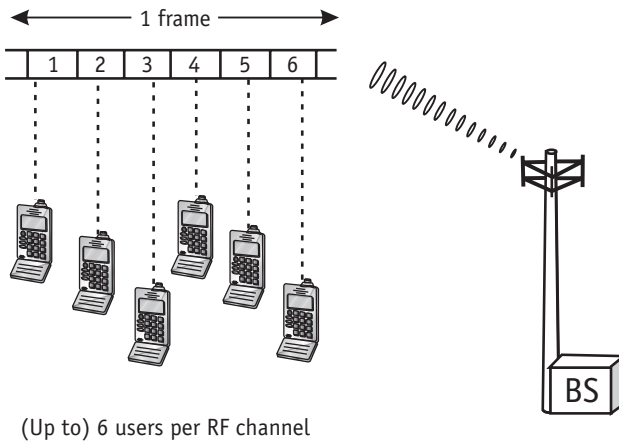

**Figure 3.7** TDMA IS-136 half rate.

### 3.3.2 Slot structure

Each IS-136 digital channel is divided into 40 msec frames each composed of six 6.67 msec time slots. Mobile phones either transmit, receive or remain idle during a time slot. The IS-136 standard describes several slot structures that are used to transfer voice and user data. These include forward speech slot, reverse speech slot, FACCH data message slot for in

band control messaging, and shortened burst slot. Each slot is composed of 324 bits (162 symbols).

Interleaving, or the continuous distribution of data bits between adjacent slots, is used to overcome the effects of burst errors due to Rayleigh fading. Diagonal interleaving is used so that the information, including errors, is distributed between adjacent slots. This distribution helps the error protection process since consecutive (burst) errors are spread, thereby enabling the error protection code to work more accurately.

### 3.3.2.1 Forward data slot

The forward data slot transfers voice and data traffic from the base station to the mobile phone. It contains 324 data bits, 260 of which are available to the subscriber. The initial field in the slot contains the synchronization field that identifies the slot number and provides timing information for the decoder. It is a standard pattern that may also be used for equalizer training. The equalizer adjusts the receiver to compensate for radio channel change (distortion). The SACCH field contains a set of dedicated bits for sending control information. The data fields carry the subscribers' voice and data information. The *coded digital verification color code* (CDVCC) is similar in function to SAT in analog cellular where each cell is referenced by a unique identifier. This helps the phone to distinguish between two cells that are using the same frequency. The slot format is shown in Figure 3.8.

Every IS-136 forward traffic channel slot format includes a *coded digital locator* (CDL) field that indicates a range of eight RF channels where the DCCH can be found. This field helps a mobile phone find a DCCH during an initial scan.

### 3.3.2.2 Reverse data slot

The reverse data slot transfers voice and data from the mobile phone to the base station. It differs from the forward data slot in that it includes guard and ramp time. During the guard time period (approximately  $123\mu\text{sec}$ ), the mobile phone's transmitter is off. Guard time protects the system from bursts being received outside the allotted time slot interval due to the propagation time between the mobile phone and cell site (see

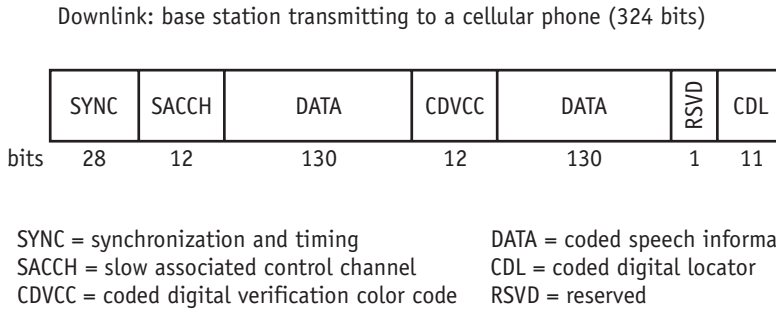
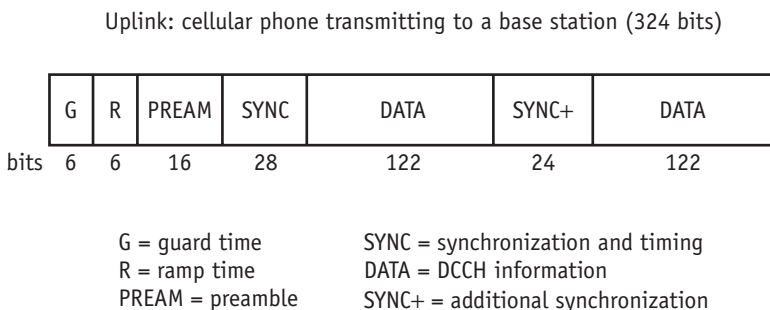

**Figure 3.8** Downlink TDMA burst format.

dynamic time alignment). Ramp time slowly turns on the transmitter to protect other mobile phones from interference (outside the allotted 30-kHz bandwidth) that occurs if a mobile phone turns on instantaneously. The synchronization word, CDVCC, and SACCH fields provide the same functions as described in the forward traffic channel slot. Figure 3.9 illustrates the slot format.

### 3.3.2.3 Shortened burst

When a mobile phone begins operating in a large diameter cell or following a hand-off between two adjacent cells of very different size, it sends shortened bursts until the appropriate timing can be established with the system. Radio link propagation time in large cells could be so long (with a round trip in excess of  $500\ \mu\text{sec}$ ) that overlapping bursts could cause significant problems. The shortened burst allocates another guard time,



**Figure 3.9** Uplink TDMA burst format.

thereby preventing received bursts from overlapping before a mobile phone's dynamic time alignment has adjusted. Figure 3.10 illustrates the format of a shortened burst slot.

Notice that there are several synchronization fields. Any two sync fields are separated by different amounts of time so that a base station receiver can simply detect the relative time the burst is being received in comparison to other bursts. If bursts are received out of their expected time periods, the base station can command the mobile phone to adjust its transmit time. After the shortened burst has been used to determine time alignment, the mobile phone will begin to use the standard reverse traffic channel slot structure to send user information.

### 3.3.2.4 FACCH data slot

When urgent control messages such as a hand-off command are sent, signaling information replaces speech information (260 data bits) in a manner similar to the blank and burst process used for control on the AMPS voice channel. The *fast associated control channel* (FACCH) message slot is identified by use of a different type of error correction coding. Initially, all slots are decoded as speech data slots, but if an FACCH message is in a speech data slot, the CRC check sum and other error detection code outputs will fail, and the message will be decoded as an FACCH data slot. This process is used so that information bits need not be dedicated to indicate whether a data slot is for speech or control. The FACCH data slot

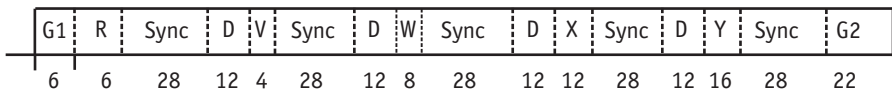

- G1 = Guard time
- R = Ramp
- Sync = Synchronization (time align code)
- D = Digital Color Code
- V = 0H
- W = 00H
- X = 000H
- Y = 0000H
- G2 = Additional guard time

**Figure 3.10** Shortened burst slot structure.

structure is identical to a speech slot, and only the data bits are FACCH data rather than digitally coded speech.

### 3.3.3 Traffic channel signaling

The DTC offers several methods of transferring control information. These can be divided into in-band and out-of-band signaling. In-band signaling replaces voice data, and out-of-band is sent simultaneously with the voice data. In-band signaling for the DTC includes FACCH. Out-of-band signaling is called *slow associated control channel* (SACCH).

#### 3.3.3.1 Slow associated control channel (SACCH)

SACCH is a continuous data stream of signaling information sent beside speech data (out-of-band signaling). SACCH messages are sent using dedicated bits in each slot, so SACCH messages do not affect speech transmission. However, the transmission rate for SACCH messages is slow. For rapid message delivery, control information is sent via the FACCH channel. The SACCH and FACCH system was designed to maximize the number of bits devoted to speech and optimize the number of bits devoted to continuous signaling.

The SACCH is allocated 12 bits per slot. A message is composed over 12 slots, resulting in a gross rate of 600 bps. The data is 1/2-rate convolutionally coded, reducing data transmission to 300 bps, including control flags and CRC. Figure 3.11 shows the SACCH signaling process.

#### 3.3.3.2 Fast associated control channel (FACCH)

FACCH control messages replace speech data with signal messages (in-band signaling). FACCH data is error-protected by a 1/4-rate convolutional coder, which increases the error protection since control messages are often sent in poor radio conditions (e.g., hand-off). FACCH messages use the entire 260 data bits of the burst, providing a gross data rate of 13 Kbps. However, the 1/4-rate convolutional coding reduces the data transmission rate to 3,250 bps. Speech quality can be degraded as more and more speech frames are replaced with signaling information, and infrastructure manufacturers are careful not to demand too many consecutive FACCH transactions during normal operation. Figure 3.12 shows FACCH signaling.

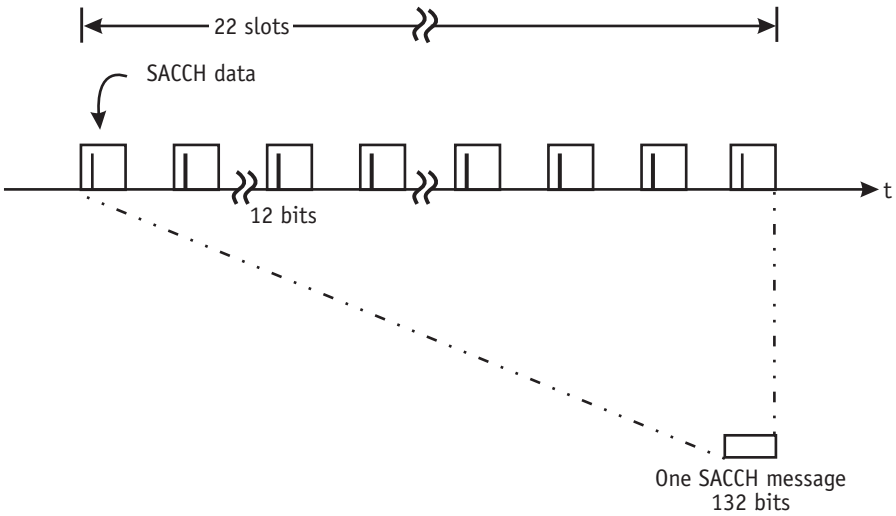

**Figure 3.11** SACCH signaling.

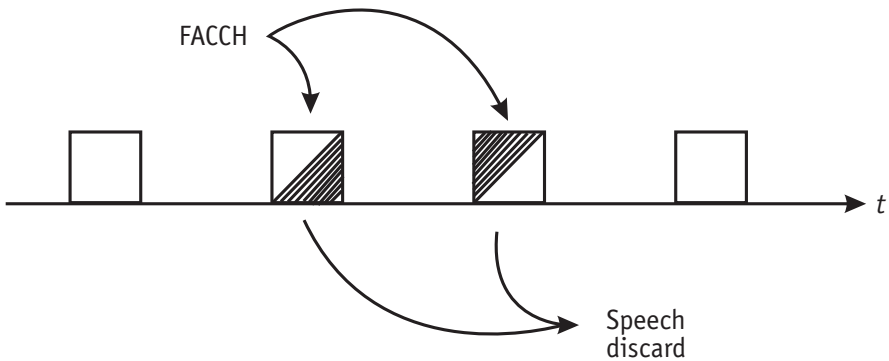

**Figure 3.12** FACCH signaling.

### 3.3.3.3 Digital verification color code (DVCC)

Each cell site in a cellular system (or localized region of the system) has its own unique DVCC code. This is used by phones to detect interference from neighboring cell sites while decoding system information. A unique DVCC for each cell site ensures that the correct mobile phone is communicating with the proper base station, since frequencies are reused in most cellular systems.

The base station sends the DVCC and adds four parity bits to the eight-bit DVCC code. This is the CDVCC. The value 00h is not used as a valid CDVCC, leaving 255 unique codes.

### 3.3.3.4 Dual-tone multifrequency signaling

Digital voice coders are not designed to handle nonspeech audio signal such as DTMF tones. As a result, they can change the amplitude relationship between one tone component and another within the DTMF signal.

To avoid speech coder DTMF distortion, a DTMF on message can command the base station or MSC to create DTMF tones. Figure 3.13 shows a user pressing key number 2 (step 1) to create an FACCH message (step 2) that indicates that digit #2 has been pressed. The receiver in the base station decodes this message (step 3) and commands a DTMF generator to create a number 2 DTMF touch tone (step 4). When the user releases the #2 key, an FACCH message is created, indicating that the #2 key has been released and that the DTMF touch tone is stopped. In addition to the PRESS and RELEASE messages, the mobile station can also send a message that contains one or more DTMF digits. This message is used for “speed dial” service or similar purposes. The duration of each digit is preset according to the industry standards.

### 3.3.4 Dynamic time alignment

Dynamic time alignment is a technique that allows the base station to receive digital mobile phones’ transmit bursts in an exact time slot. Time alignment keeps different digital subscribers’ transmit bursts from colliding or overlapping. Dynamic time alignment is necessary, because

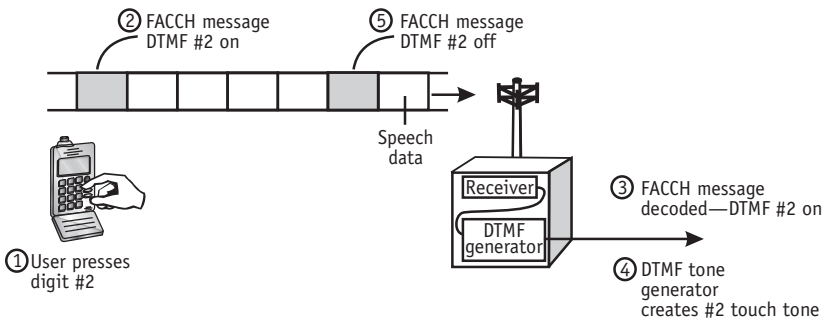

Figure 3.13 DTMF signaling.

subscribers are moving or scattered within the cell coverage, and the arrival time of signals at the base station depends on their changing distance from the base station. The greater the distance, the more delay in the signal's arrival time. Dynamic time alignment adjusts for differences in the signal travel time according to each mobile phone's distance from the base station.

The base station adjusts for the delay by commanding mobile phones to alter their relative transmit times based on their distance from the base station. The base station calculates the required offset from the mobile phone's initial transmission of a shortened burst in its designated time slot (necessary only in large diameter cells where propagation time is long). To account for the combined receive and transmit delays, the required timing offset is twice the path delay. The mobile phone uses a received burst to determine when its burst transmission should start. The mobile phone's default delay between receive and transmit slots is 44 symbols, which can be reduced in 1/2-symbol increments to 15 symbols. Figure 3.14 shows the need for time alignment.

### **3.3.5 Mobile assisted hand-off (MAHO)**

MAHO is a system in which the mobile phone assists the MSC with hand-off decisions by sending radio channel quality information back to the system. In existing analog systems, hand-off decisions are based only on measurements of mobile phones' signal strength made by receivers at the base station. IS-136 systems use two types of radio channel quality information: signal strength of multiple neighbor channels and an estimated bit error rate of the current channel. The bit error rate is estimated using the result of the forward error correction codes for speech data and call processing messages. Having the mobile phone report quality information also allows for measurements of the downlink quality that are not possible from the base station.

The system sends the mobile phone a MAHO message containing a list of radio channels from up to 24 neighbor cells. During its idle time slots, the mobile phone measures the signal strength of the channels on the list including the current operating channel. The mobile phone averages the signal strength measurements over a second, then continuously sends MAHO channel strength reports back to the base station every

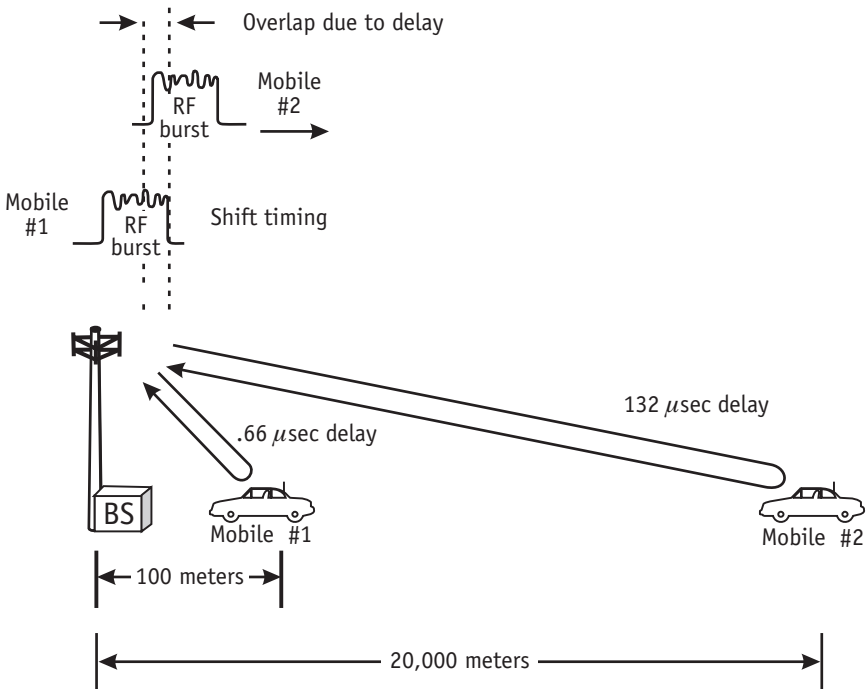

**Figure 3.14** Dynamic time alignment.

second. The system combines the MAHO measurements with its own information to determine which radio channel will offer the best quality, and it initiates hand-off to the best channel when required. Figure 3.15 illustrates the MAHO process.

## 3.4 The digital control channel environment

The digital control channel is used to convey call setup information and to provide the platform for enhanced services in an IS-136 system. This requires signaling, messaging, and an advanced radio channel structure.

### 3.4.1 DCCH basic operation

The DCCH is introduced into the wireless system by defining one DCCH slot pair on a frequency that contains existing DTCs. These DCCHs are

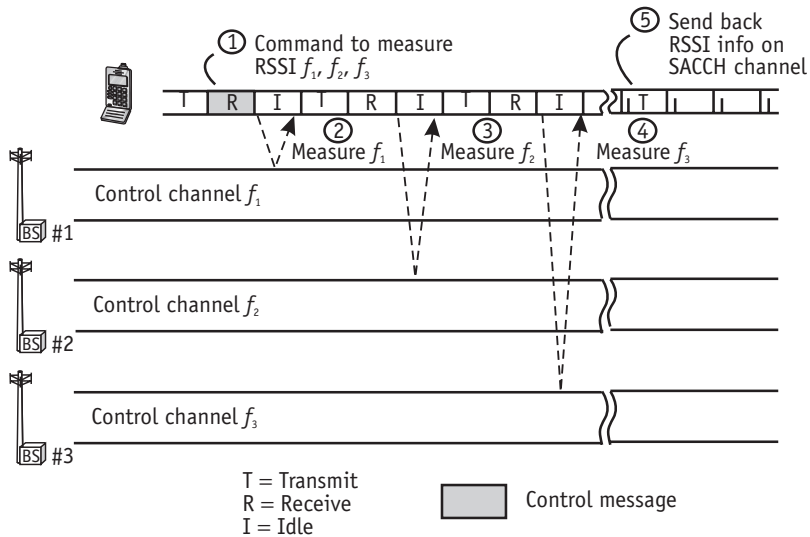

**Figure 3.15** Mobile assisted hand-off.

not restricted to the 21 channels used by the ACCs and can be anywhere in the 800- or 1,900-MHz bands. DCCH capable phones will monitor (camp on) a DCCH instead of an ACC in each sector of a system that supports IS-136 services. DCCH-capable phones will scan for this channel, gain synchronization, and begin to decode the information provided over a broadcast control channel on the DCCH. The DCCH will serve as the phone's control channel until the phone finds another cell that is more appropriate. Figure 3.16 shows the 1,4 slot pair used for a DCCH.

The DCCH-capable phone will receive pages, send originations, and communicate with the system on the DCCH. After receiving a page or performing a call origination, a traffic channel is then designated for the duration of the call. That is, after call setup, the cellular phone will retune to the DTC or analog voice channel and the conversation will take place. At call completion, the phone will return to the DCCH instead of the ACC. If no DCCH is available, the phone can obtain service on an ACC.

### 3.4.2 DCCH burst format

The TDMA DTCs and the DCCHs both use the standard TDMA frame structure, which uses three slot pairs to allow three digital conversations

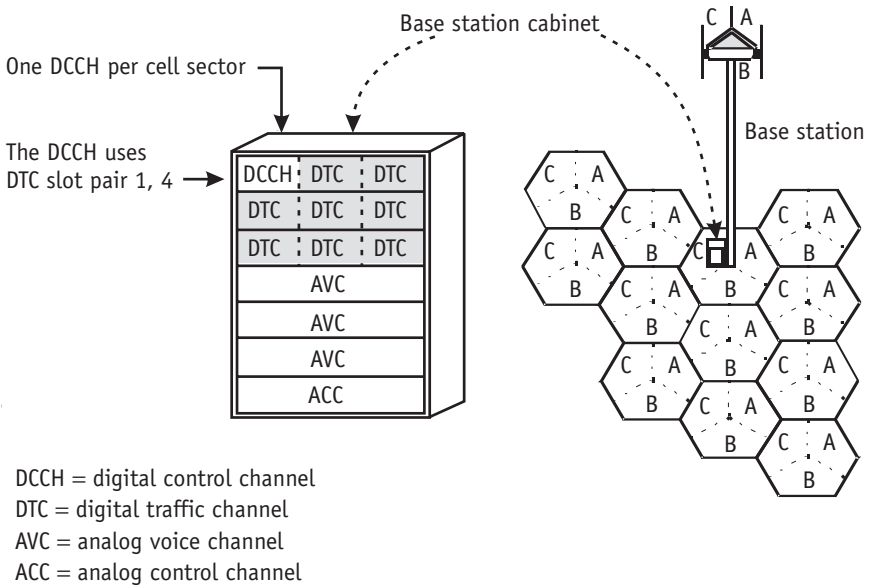

**Figure 3.16** IS-136 DCCH operation.

to be carried on one frequency. One of these slot pairs is used for a full-rate DCCH in each sector of a cell. Generally only one slot pair is required for a DCCH in each cell sector to serve as the control link for the call control information. This means that all the control signaling is performed in the same bandwidth as one DTC.

### 3.4.2.1 Forward control channel slot (downlink burst)

The IS-136 specification defines a downlink burst format for the DCCH. Figure 3.17 shows the IS-136 DCCH burst format.

The downlink fields of the DCCH burst differ from those of the DTC burst in the following ways:

- The SACCH field is replaced by the *shared channel feedback (SCF)* field. This field is a collection of flags used as a method of control and acknowledgment of information sent from the phone to the base station.
- The voice field data is replaced by DCCH data.

Downlink: base station transmitting to a cellular phone (324 bits)

SYNC	SCF	DATA	CSFP	DATA	SCF	RSVD
28	12	130	12	130	10	2

SYNC = synchronization and timing  
 SCF = shared channel feedback  
 DATA = DCCH information

CSFP = coded superframe  
 RSVD = reserved bits

**Figure 3.17** DCCH downlink burst format.

- The CDVCC field is replaced by a frame-counting field called the *coded superframe phase* (CSFP). This field indicates to the phone which frame in the superframe is currently being transmitted.
- The RSVD field is replaced by the remaining bits of the SCF field.

Because the DCCH burst copies the basic TDMA burst structure used for the traffic channels, a DCCH will be perceived as a normal traffic channel by a non-DCCH-capable phone.

### 3.4.2.2 Reverse control channel slots (normal and abbreviated)

The base station has to treat each uplink DCCH burst of data from a phone as a unique transmission and has to achieve time alignment and bit synchronization on each DCCH burst. A *preamble* (PREAM) sequence and an additional *synchronization* (SYNC+) word is placed in each uplink packet to enable the base station to lock onto single bursts of data from phones and decode the uplink information.

The time alignment methods used for the traffic channels, which rely on a symbol-by-symbol advance or retreat of consecutive transmissions for the phone, are not possible on the uplink DCCH because of its single-burst nature. Therefore, to prevent a difference in transmit times from causing a misalignment of received bursts at the base station, there are two uplink burst lengths—a normal burst for small cells and an abbreviated burst for large cells where time alignment might be an issue. The appropriate burst length to use is set by the system operator and is announced to a phone in the broadcast information for each cell.

An abbreviated burst is used to correct the relative time offset from near and distant cellular phones within a large cell. Using the shorter burst length in large cells reduces the probability of the burst overlapping a frame when it is received at the base station. Figures 3.18 and 3.19 show the normal and abbreviated DCCH slot formats for the normal control channel uplinks slot structure.

The PREAM is used for timing. It is also used by the base station to set the receiver amplifier to avoid signal distortion. The SYNC field is a known pattern that allows the base station to find the start of the incoming TDMA burst. The data field, which is the payload, is divided into a two-part field. The SYNC+ is another fixed bit pattern that provides additional synchronization information for the base station.

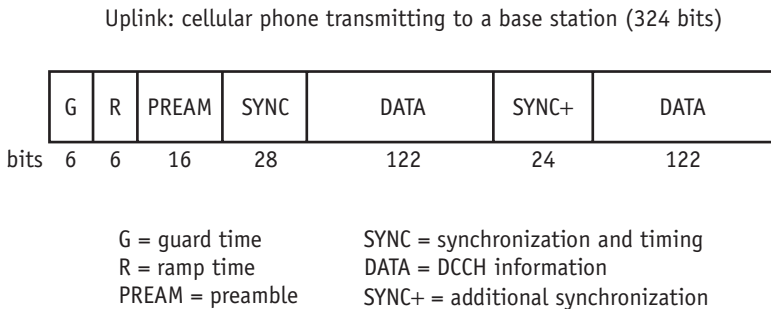

**Figure 3.18** DCCH normal uplink burst format.

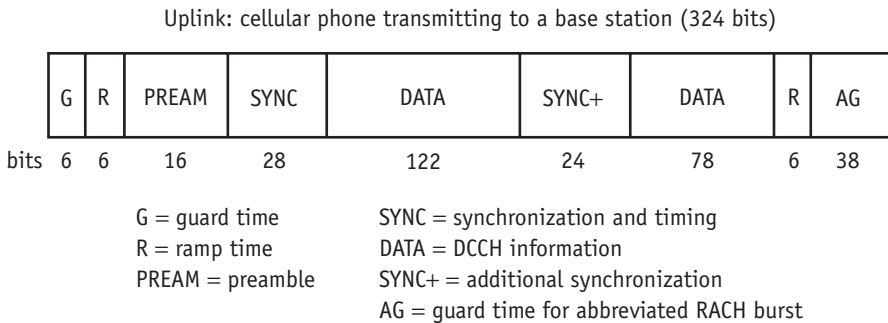

**Figure 3.19** DCCH abbreviated uplink burst format.

### 3.4.3 Superframe and hyperframe formats

Superframe and hyperframe formats are used to multiplex logical groups of information together and to provide a known repeatable sequence on the air interface. This enables a phone to retrieve information quickly and to develop a sleep mode in which the phone only needs to wake up at pre-defined instances to receive messaging.

#### 3.4.3.1 Superframes

A superframe is made up of sixteen sequential 40-ms TDMA frames equivalent to 32 consecutive TDMA blocks at full rate. Only slots one and four are used to carry DCCH information; this creates a sequence of 32 DCCH carrying bursts spread through 96 TDMA bursts. Each DCCH burst in the superframe is designated for either broadcast, paging, *short message service* (SMS) messaging, or access response information. The superframe structure shown in Figure 3.20 is continuously repeated on the DCCH channel.

The *broadcast channel* (BCCH) shown in Figure 3.21 is split between a *fast BCCH* (F-BCCH) used for mandatory information with a guaranteed data throughput, and an *extended BCCH* (E-BCCH) used for additional information of a less critical nature. These BCCHs are indicated respectively as F and E in Figure 3.21.

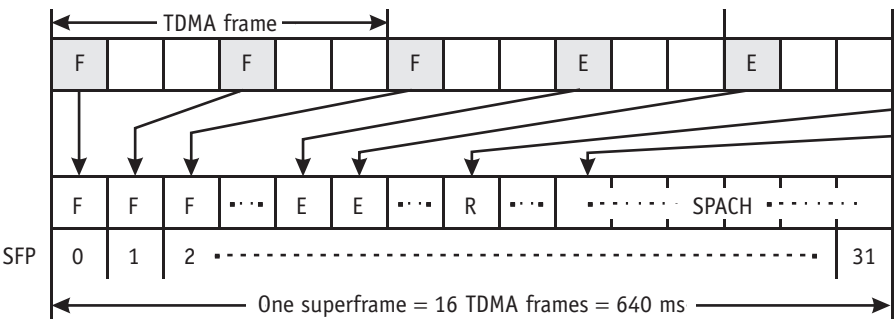

- BCCH = broadcast channel
- F = fast broadcast channel (F-BCCH)
- E = extended broadcast channel (E-BCCH)
- R = reserved slots
- SFP = superframe phase
- SPACH = paging channel (PCH)
- SMS messaging channel (SMSCH)
- Access response channel (ARCH)

Figure 3.20 Superframe structure.

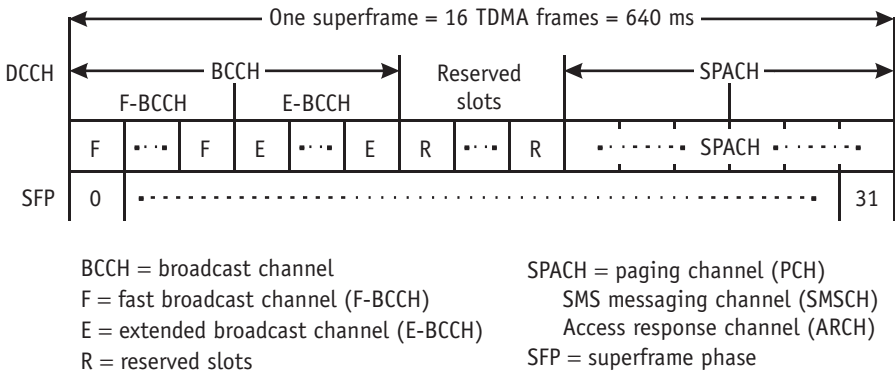

**Figure 3.21** Logical channels multiplexed onto the superframe.

The SPACH channel shown in Figure 3.21 is comprised of the *paging channel* (PCH), the *SMS messaging channel* (SMSCH), and the *access response channel* (ARCH). These logical channels are described in more detail later.

The superframe is created by multiplexing the broadcast and other logical channels in a repetitive, ordered sequence onto a physical DCCH burst on the downlink (base station to phone). Figure 3.21 shows the channels multiplexed onto the superframe.

Table 3.3 defines the number of slots that can be supported for each logical channel. This allows the superframe to be tuned to meet the needs of specific environments. For example, an operator may use very few DCCH neighbors and would prefer to provide more bandwidth for paging messages. The superframe structure is flexible and is broadcast to phones when a DCCH is first acquired. The *superframe phase* (SFP) increments every superframe slot, starting at 0 on the first F-BCCH slot and counting modulo 32.

*Note:* All of the time slots on the uplink (phone to base station) are used for system access by the phone on the RACH (random access) logical channel. This is described in Section 3.5.3.

A phone learns the structure of the superframe from information transmitted in the F-BCCH. When a cellular phone first finds a DCCH, it must determine the slot in the superframe that is actually being monitored. This is achieved by monitoring the CSFP field in the DCCH burst. When the first slot of the superframe is encountered, the phone can

**Table 3.3**  
Superframe Slot Allocations

Slots	Full-Rate DCCH		Half-Rate DCCH	
	MIN	MAX	MIN	MAX
F-BCCH (F)	3	10	3	10
E-BCCH (E)	1	8	1	8
Reserved (R)	0	7	0	7
SPACH	1	$32 - (F + E + R)$	1	$16 - (F + E + R)$

decode the F-BCCH information (since it is always transmitted first) and ascertain the structure of the superframe. The phone then knows the slot usage for the rest of the superframe and can decode the E-BCCH and SPACH information.

### 3.4.3.2 Hyperframes

A hyperframe is made up of a primary and secondary superframe as shown in Figure 3.22. The hyperframe length consists of 192 TDMA bursts. Sixty-four of these (or every third) are used at full rate for DCCH

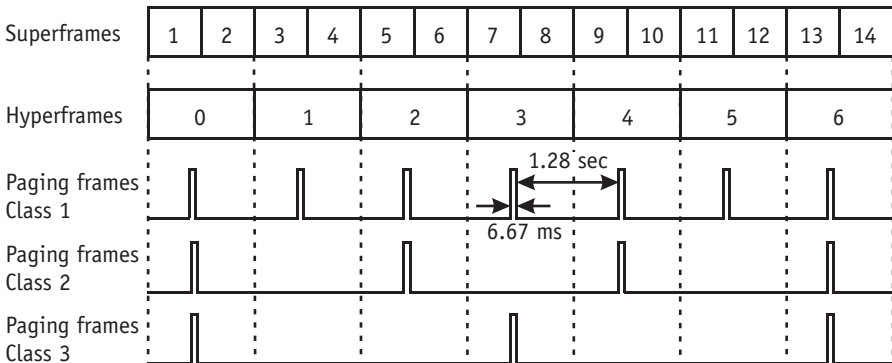

Paging frame classes 4 through 8 are not shown

**Figure 3.22** Hyperframes showing paging frame classes.

information to maintain the same burst usage as a TDMA traffic channel. By repeating the DCCH information in each hyperframe, the hyperframe structure allows a cellular phone to read broadcast-channel information on adjacent, nonsynchronized DCCHs and scan for another DCCH on a different frequency, without missing a page on its own DCCH.

To enhance the readability of pages under severe radio conditions, all pages are repeated at the corresponding time slot in the second superframe. By having a specified page repeat, if a phone cannot correctly decode the first assigned PCH slot in the first half of the hyperframe, it can read the corresponding PCH slot in the secondary superframe (640 ms later). In addition, a level of redundancy is built into the DCCH so that burst errors—that is, a cluster of closely spaced bits that are incorrect—will not affect both superframes.

### 3.4.3.3 Paging classes

Paging frame classes determine the time period (in hyperframes) in which the system can potentially page a phone. Since each phone is assigned a particular paging slot on the DCCH superframe, the phone knows precisely when it is likely to get paged and need only monitor that particular paging slot. This is the basis of the sleep mode described in Section 3.4.3.4.

There are eight paging frame classes supported, ranging from one to 96 hyperframes, which represent 1.28 to 123 seconds between paging opportunities. The eight classes comprise 1, 2, 3, 6, 12, 24, 48, and 96 hyperframes duration. Voice services will use lower paging-frame classes because the higher paging-frame classes, reserved for nonvoice applications, will introduce unacceptable call-setup delay.

### 3.4.3.4 Sleep mode

Since the superframe structure is known, the phone only needs to monitor downlink DCCH information on its predetermined paging slot. This will provide extended periods of time in which the phone can power down some of its circuitry and sleep between paging opportunities, thus saving battery standby time.

While a phone is in idle mode and waiting for pages (for either a voice call or teleservice message), indicators in the time slots used for paging

inform the phone about broadcast information changes. Thus, as long as the broadcast information does not change, the phone only has to wake up and read its paging slot and perform channel measurements. This provides for an efficient sleep mode in conjunction with a fast response to broadcast updates (for instance, during cell changes).

Since phones spend most of their time waiting for a page, the PCH structure directly affects their *sleep* time. The IS-136 PCH was designed to maximize the sleep time available to a phone, thereby increasing the battery standby time.

### 3.5 Logical channels

Logical channels have been created in IS-136 to organize the information flowing across the air interface as shown in Figure 3.23.

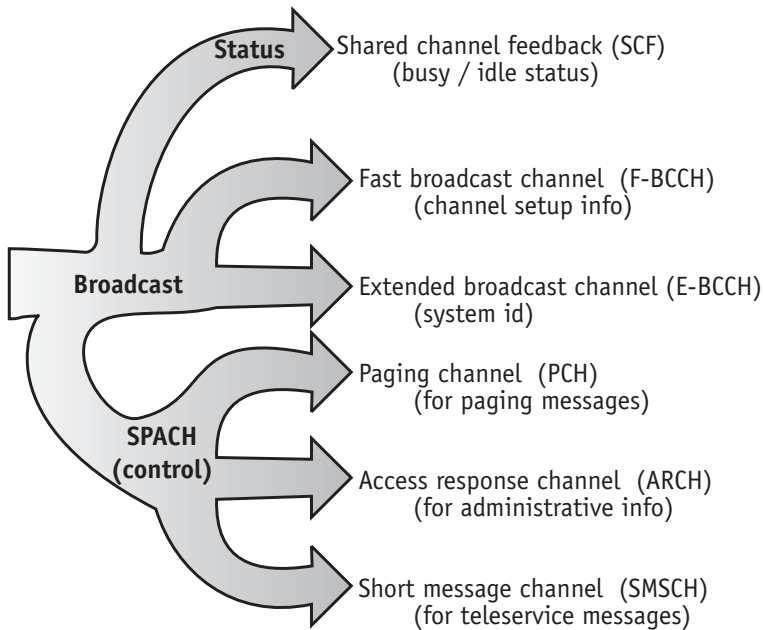

**Figure 3.23** Logical channels.

### 3.5.1 Broadcast channel (BCCH)

The BCCH continuously provides information about the system configuration and the rules that a cellular phone must follow at system access. The BCCH logical channels are multiplexed onto the physical DCCH downlink channel as part of the superframe. The BCCH information includes SID, neighbor lists of other DCCHs for DCCH reselection, DCCH frame structure, and other system information.

#### 3.5.1.1 Fast BCCH and extended BCCH

The BCCH channel is divided into F-BCCH and E-BCCH. Another dedicated channel, the *short messaging service BCCH* (S-BCCH), is being created to provide a broadcast messaging service.

The first timeslot of a superframe is always an F-BCCH slot. The F-BCCH information is sent in its entirety once every superframe (640 ms), whereas a complete set of E-BCCH information might span several superframes. The F-BCCH channel is used for mandatory, time-critical system information requiring a fixed repetition cycle. The information sent on this channel relates to SID and parameters needed by a cellular phone in determining the following:

- Structure of the superframe;
- System on which the phone is camped;
- Registration parameters;
- Access parameters.

The E-BCCH channel is used for additional system information that is less time-critical (in terms of a phone needing to camp) and that does not require a guaranteed rate (for example, neighbor cell lists).

### 3.5.2 SMS, paging, and access channel (SPACH)

The *SMS, paging, and access channel* (SPACH) provides mobile phones with paging and system access parameter information. The SPACH channel is divided into a paging channel (PCH), an access response channel (ARCH), a short message service (SMS), and a point-to-point messaging channel (SMSCH).

### 3.5.2.1 Paging channel (PCH)

The PCH is used to transfer call setup pages to the phone. A cellular phone is allocated to a particular paging slot (part of the SPACH) in a superframe according to its *mobile station identity* (MSID). This strategy will always place a specific phone in the same paging slot on any DCCH with the same structure. In addition, this method minimizes paging congestion across the air interface, since the paging slots for all the phones camped on any particular DCCH will be randomly distributed across the total number of available SPACH slots.

### 3.5.2.2 Access response channel (ARCH)

The ARCH is used to send system responses (such as channel assignment commands) and administrative information from the system to the phone.

### 3.5.2.3 SMS channel (SMSCH)

The SMSCH is used to transfer point-to-point teleservice data to and from the mobile phone. This data can belong to a CMT text message, OAA NAM data, *over-the-air programming* (OAP) intelligent roaming information, or a *general UDP teleservice* (GUTS) packet.

## 3.5.3 Random access channel (RACH)

The *random access channel* (RACH) is a shared channel resource used by all DCCH-capable mobile phones when they attempt to access the system. The RACH is the only logical channel on the uplink of the DCCH. Uplink RACH messages could be, for example, a phone's response to an authentication request or a MS acknowledgment to a short message delivery.

The RACH supports both contention-based (random) and reservation-based (scheduled) accesses from phones. Contention-based access means that more than one phone may attempt an access on the same channel at once and the accesses may collide. If this occurs, the phones that did not manage to gain access will enter a retry state. Reservation-based access can be used during sequential transmissions from a particular phone where the system announces to all phones which one is allowed access at a certain point in time. This reserves the RACH channel for the duration of the uplink message and stops interruptions by other phones.

The uplink RACH mode is made possible by introducing SCF in the downlink. By reading the SCF information sent in every downlink burst, the phones will know the status of the next corresponding uplink burst, that is, whether it is idle, busy, or reserved.

The full-rate DCCH is defined to consist of six RACH subchannels or TDMA blocks to allow for base station and phone processing as shown in Figure 3.24. The phone monitors the downlink subchannel (in this example, subchannel 1) and waits for the SCF flag to show idle (described in Section 3.5.4). When this happens, the phone knows that the next uplink subchannel 1 will be available, and the phone transmits the first burst in that subchannel. The phone then waits for the next downlink subchannel 1 to find out if the uplink transmission was successful and whether it should send the next burst. This continues until the whole message has been sent.

This activity is only occurring on one of the subchannels. Other phones could be accessing the system simultaneously on subchannels 2 through 6 on the same DCCH.

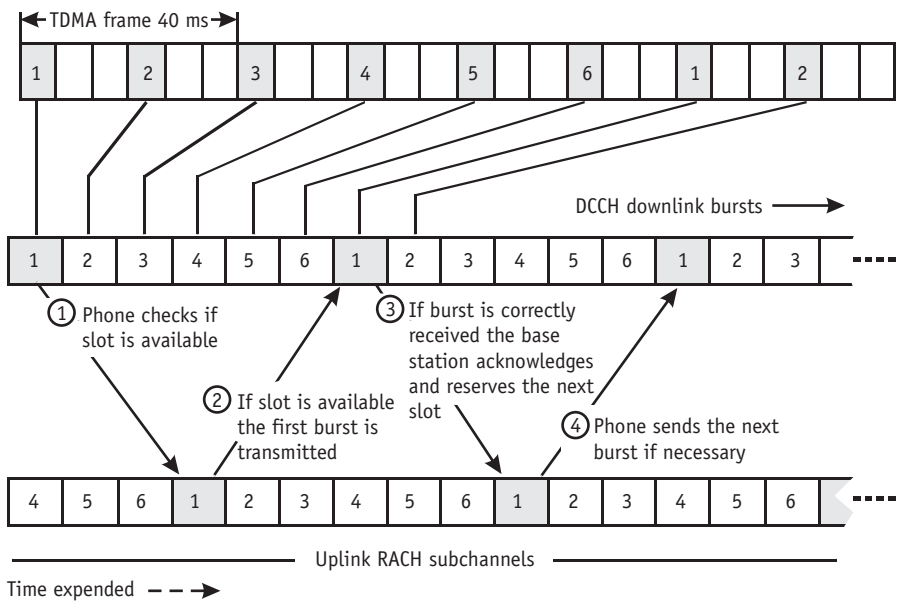

**Figure 3.24** IS-136 system access on RACH channel.

### 3.5.4 Shared channel feedback (SCF)

The information sent on the uplink DCCH (from a phone to the base station) is controlled and acknowledged by the SCF flags located in the downlink.

The SCF downlink information provides a real-time indication of the status of every uplink timeslot and informs all phones of the usage at any particular time. In this way, the SCF provides a collision-prevention mechanism for the uplink RACH channel. This combined uplink and downlink flow of information serves to enhance the throughput capacity of the RACH. In addition, the SCF flags provide error correction for the uplink RACH channel by indicating whether or not any given burst of an access attempt has been successfully received by the system.

The SCF field indicates the status of the RACH using the *busy-reserved-idle* (BRI), *partial echo* (PE), and *received/not received* (R/N) indicator fields, which are discussed in Sections 3.5.4.1–3.5.4.3.

#### 3.5.4.1 Busy-reserved-idle field

The base station signals the availability of the RACH by setting one of the following bits of the SCF flags.

- B: Busy, or not accepting RACH traffic;
- R: Reserved, or currently being used by a phone;
- I: Idle, or phone access available on request.

Subsequently, a phone will be able to determine if it can begin an uplink transmission.

#### 3.5.4.2 Partial echo field

This SCF field contains a PE derived from a phone's MSID, which echoes back part of the phone ID on the downlink. In this way, all phones will know which phone has use of the RACH.

In the case of a collision during a contention-based access, the PE field is also used to indicate which phone was granted access to the system.

### 3.5.4.3 Received/not received field

The R/N field bits are used to indicate whether the uplink message was received correctly. This field provides the *automatic retransmission request* (ARQ) error-correction function on the uplink RACH.

## 3.6 Layered structure

The IS-136 air interface is structured in different layers, each with specific purposes. This conceptual split makes it easier to understand the interactions between the base station and phone across the air interface. Four layers can be identified in IS-136:

1. A physical layer (layer 1), dealing with the radio interface, bursts, slots, frames, and superframes;
2. A data link layer (layer 2) that handles the data packaging, error correction, and message transport;
3. A message layer (layer 3) that creates and handles messages sent and received across the air;
4. Upper application layers, which represent the teleservice currently being used, such as CMT, OATS, or GUTS.

The IS-136 layered structure is shown in Figure 3.25. The structure of IS-136 simplifies introduction of future services using the same DCCH platform because the lower layers in the air interface protocol (e.g., the radio interface, data management, and messages) remain unchanged.

Figure 3.26 shows how one layer-3 message is mapped into several layer-2 frames and how a layer-2 time frame is mapped onto a time slot. The time slot is further mapped onto a DCCH channel. Figure 3.26 illustrates how information is passed from layer to layer down through the stack until a TDMA burst is created, ready for transmission. At the receiving end, information is stripped off as needed as the message is passed up to the application.

The layer-3 message shown in Figure 3.26 can be an uplink registration, a downlink SMS, a page response, or a broadcast message. The length of a layer-3 message is determined by a layer-3 length indicator, which is carried as part of the layer-3 header. The length of a layer-2

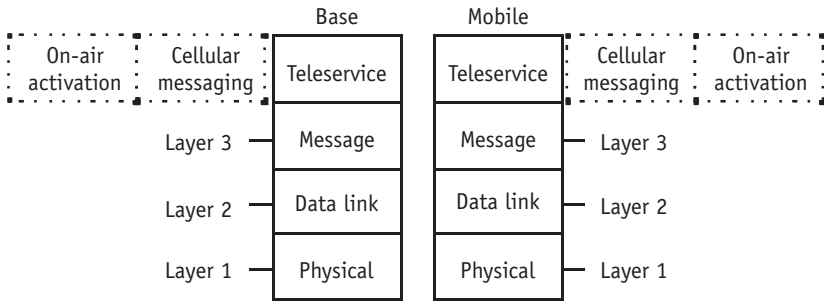

Layer 3 = messages and information elements  
 Layer 2 = message transport, organization, and error correction  
 Layer 1 = bursts, frames, coding, and RF

**Figure 3.25** IS-136 air interface model.

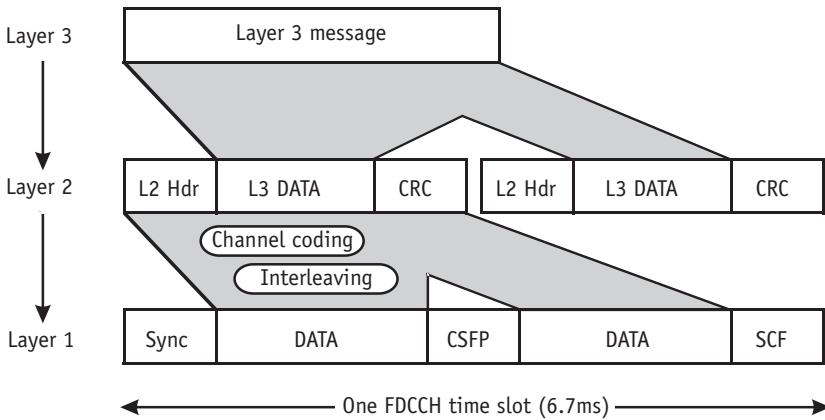

**Figure 3.26** Layered 3.2.1 mapping.

frame is fixed, determined by the specific logical channel. *Cyclic redundancy check* (CRC) tail bits are added to the layer-2 frames before channel encoding.

### 3.6.1 Physical layer (layer 1)

The primary function of the physical layer is to transport (deliver) layer-2 information on TDMA slots, which comprise the fundamental

transmission units sent over the wireless physical media. The burst structure, TDMA framing, superframes, hyperframes, and radio interface are all part of the physical layer.

### 3.6.2 Data link (layer 2)

Layer 2 is considered the data link layer. It provides framing and support for higher layer messages and attempts to ensure error-free transfer of layer-3 messages across the air interface. Layer-2 frames also contain overhead information for layer-2 protocol operation, handle retransmission protocols, and perform segmentation and assembly of layer-3 messages.

Each layer-2 frame is mapped into a single physical layer slot with the addition of error coding (CRC error protection) and overhead information (header information describing the type of logical channel being used). In addition, layer-2 frames allow both acknowledged and unacknowledged ARQ modes to be invoked for certain messages.

Because of the general point-to-point nature of messages sent on the SPACH logical channels, layer 2 is designed to carry the MSID to indicate the phone identity of the message recipient. The specified layer-2 protocol allows for up to five distinct MSIDs to be included within a single layer-2 frame. This effectively allows for up to five phones to be paged in one burst if 24-bit MSIDs are used. The MSID used to identify a phone can be either the MIN, the *temporary MSID* (TMSI), or the *international MSID* (IMSI), depending on the system capability (see “Identity Structures” in Section 3.8).

### 3.6.3 Transport (layer 3)

Layer-3 messages include information for, among others, the following:

- Registration;
- Paging;
- DCCH structure;
- Call release information;
- *Relay data* (R-data) transport for teleservices;

- Relay of higher layer information for future applications;
- Proprietary signaling.

Layer-3 messages are put into layer-2 packets that indicate the type of layer-3 information, the message length, the cellular phone to which the message is intended, and other administrative information. A layer-3 message is parsed into as many layer-2 frames as needed and packed as tightly as possible (message concatenation) to achieve throughput capacity.

### **3.6.4 Application layers**

Special layer-3 data packets (R-data packets) are reserved for the transport of higher layer application information. These R-data packets are identical in structure, regardless of the application they are supporting.

By using the R-data packets, the air interface becomes transparent for future applications using the same transport mechanism, and the time to market for those features can be greatly reduced.

CMT is one of the applications supported by the IS-136 protocol. Messages from this application, which contain information regarding alphanumeric paging, display, and delivery options, are transferred across the air interface in R-data packets.

### **3.6.5 Error procedures**

Owing to the harsh radio environment—error detection and correction methods and procedures are incorporated into the digital control channel to ensure robust operation and performance.

#### **3.6.5.1 Interleaving**

The interleaving process takes blocks of bits in a burst and mixes them together so that any burst errors introduced by the radio path are spread through the resulting block of data, thereby making the errors easier to correct. The receiving end reverses the procedure, deinterleaving the data and retrieving the original bit sequence.

Intraburst interleaving is the only type of interleaving performed. Interburst interleaving across different TDMA bursts as used on traffic

channels is not used on the DCCH, since it would significantly decrease sleep mode efficiency and eliminate the single burst nature of the RACH and PCH.

#### 3.6.5.2 Convolutional coding

Rate 1/2 convolutional coding is used for all downlink logical channels. Layer-1 fields, such as the SFP in the TDMA burst, are encoded using a shortened (15,11) Hamming code. This is the same correction method used for the CDVCC and CDL on traffic channels.

#### 3.6.5.3 Automatic repeat request (ARQ)

ARQ operation is supported for the ARCH and DTC to provide enhanced data protection. ARQ is an acknowledgment process in which consecutive blocks of a message are grouped together and a results burst is returned. The sending end can then retransmit blocks that were received incorrectly.

The ARCH provides a layer-2 selective-repeat ARQ mechanism whereby ARQ MODE packets can be used to send layer-3 information with an increased level of data integrity. Each ARQ MODE packet contains a *frame number* (FRNO) and a *transaction identifier* (TID) field to identify segments for retransmission.

#### 3.6.5.4 Shared channel feedback

The information sent across the uplink physical layer is controlled and acknowledged by the SCF field located in the downlink. This field consists of R/N flags to acknowledge the success of the last uplink transmission. The phone can retransmit information that was incorrectly received by the base station.

## 3.7 Digital control channel operations

Phones that use IS-136 TDMA systems must perform ancillary tasks in order to find a suitable DCCH, inform the system of their presence (registration), make calls, and send and receive teleservice messages. Phones

must also be authorized and validated (in the authentication process) prior to accessing a system.

### **3.7.1 System and control channel selection**

Unlike ACCs, which are generally confined to channels 313 to 333, a DCCH can be placed anywhere in the 800- or 1,900-MHz spectrum. This means that a DCCH-capable phone will need to execute a more complex scanning procedure to find a DCCH.

#### **3.7.1.1 Intelligent roaming**

IS-136 phones that are capable of operating at 800 MHz and 1,900 MHz (dual-band phones) must determine the correct frequency band to scan for DCCHs prior to obtaining service. This operation must be performed quickly after power-up to achieve a fast time to service. Chapter 8 describes intelligent roaming in more detail.

#### **3.7.1.2 DCCH scanning**

Several schemes are available to help a DCCH-capable phone find service on initial power-up. Figure 3.27 provides a flowchart showing a possible DCCH scanning and locking process.

#### **3.7.1.3 Camping criteria**

There are certain signal strengths that need to be met before a DCCH is considered a suitable control channel. These are explained in Appendix C.

#### **3.7.1.4 DCCH history list**

DCCH-capable phones might maintain a history list of last-used DCCH frequencies; that is, the phone will store in memory the last channels that were used to acquire DCCH service. The phone will then scan those channels first in an attempt to find a DCCH.

#### **3.7.1.5 Analog control channel overhead message**

ACCs have an overhead message announcing the DCCH frequency; the message will directly point a DCCH-capable phone to the DCCH in that cell. If this message is not present on the ACC, the phone will

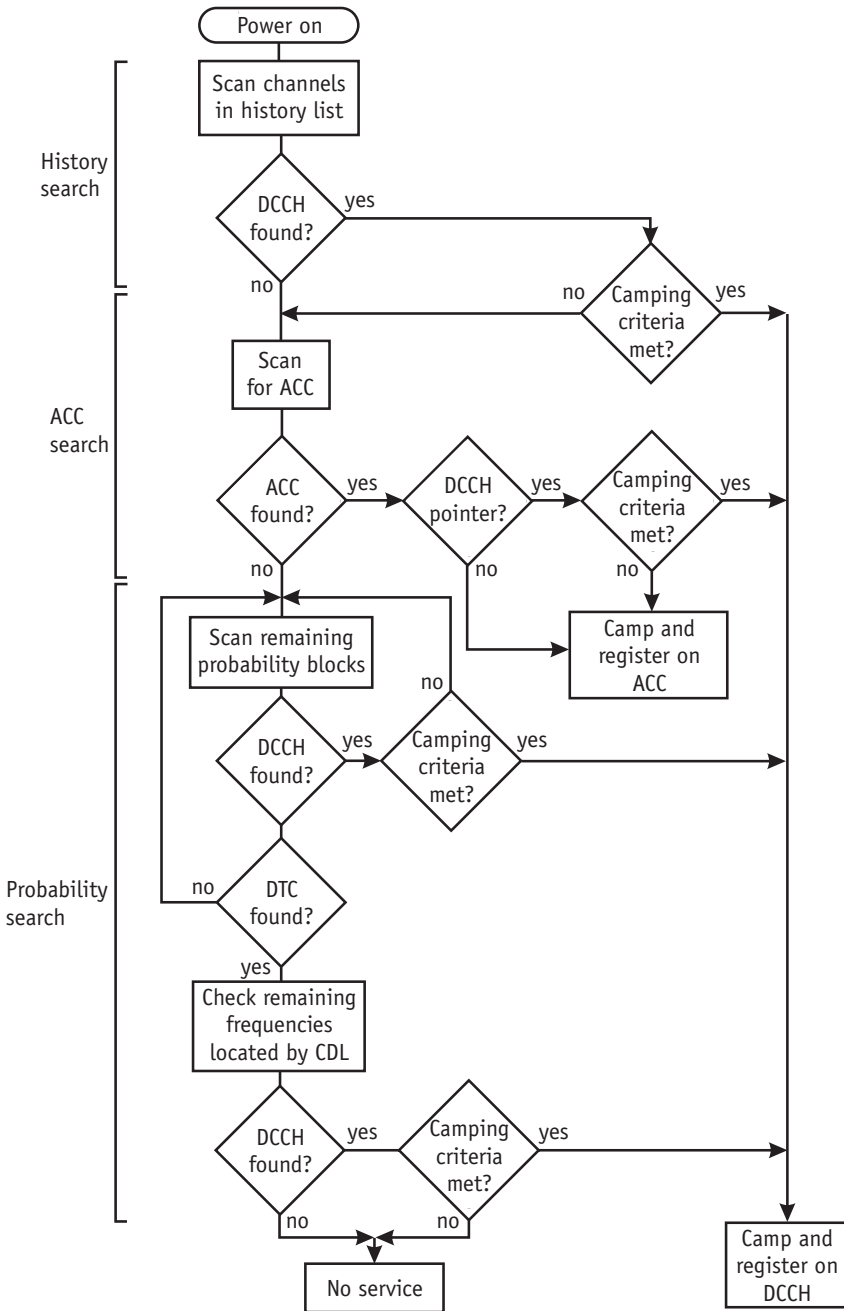

**Figure 3.27** DCCH scanning and locking processes.

assume that the cell does not support DCCH operation and will then register and camp on the ACC.

#### 3.7.1.6 Digital traffic channel locator

DTCs contain a DCCH locator in each burst. This locator will be used while a phone is scanning the frequency band looking for a DCCH. If the phone finds a DTC, it will know to decode the last 11 bits of the channel, which will point to a block of eight frequencies, one of which will be the DCCH for that cell.

#### 3.7.1.7 Probabilistic-channel assignment

Probabilistic-channel assignment is a process that can be used to find a DCCH in a system where no ACCs are present—for example, in the 1,900-MHz frequency band. If, after searching the last-used channels and scanning the ACCs, no DCCH is located, the phone may start a scan of the frequency band to find a DCCH.

#### 3.7.1.8 Call release message

Phones are given DCCH frequency information on analog and digital call releases. Each call-release message to DCCH-capable phones in a DCCH-equipped system will contain a channel number that will direct the phone to the serving DCCH in that cell.

#### 3.7.1.9 Acquiring service on a DCCH

After satisfying the signal-strength requirements for camping on a DCCH, a phone must read the FBCCH prior to acquiring service. The phone has to read a full cycle of the broadcast information to gain knowledge of the system type, registration abilities, features supported, and neighbor information. If required, the phone can register and then enter a camping state, where it will be available to make calls, receive calls, register, receive teleservice messages, scan for new control channels, or be authenticated.

### 3.7.2 System and control channel reselection

In the AMPS cellular system, phones only reassess the best ACC for service when the signal strength of the serving control channel drops below a certain threshold, or at approximately five-minute intervals.

When this threshold is reached, analog phones generally scan the pre-determined block of 21 ACCs and enter the idle state on the strongest control channel to register and to receive pages for incoming calls. Therefore, only the strongest new ACC is the viable candidate when the signal strength on the serving cell falls below a satisfactory level.

This situation might cause a problem when the system designer is attempting to make phones prefer a microcell that is at a lower transmit power than an umbrella macrocell, or when more control is required between cells in high traffic areas. In addition, microcells might not carry the traffic they were intended to carry if they cannot be acquired by phones.

Digital control-channel reselection is the function that allows a DCCH-capable phone to perform the following functions.

- Scan nonstandard control channels: Since a DCCH can be anywhere in the cellular band, the reselection process uses broadcast neighbor lists in each cell to tell a phone which neighboring DCCHs are to be found.
- Scan neighbor DCCHs in real time: Scanning is ongoing, not just when the serving signal strength degrades. This *reselection* enables a phone to build up a more accurate picture of its environment by performing more frequent evaluations of the surrounding neighbor channels.
- Make decisions on how to treat each neighbor: Based on broadcast parameters, a DCCH phone might opt to gain service from a cell that is not the strongest but is a sufficiently strong neighbor. This is the basis of a hierarchical cell structure (HCS).

In this way, reselection can be defined as the change of control channel during the camping state and can be compared to hand-off, which is the change of traffic channel during a call.

It is important to note that reselection can occur between two DCCHs or from a DCCH to an ACC. Reselection from an analog control to DCCH case is not available, since neighbor lists are not supported on the ACCs. However, a phone will use the DCCH pointer on the ACC to retune to a DCCH.

### 3.7.3 Hierarchical cell structures (HCS)

Since a geographical area might be covered by a mix of macrocells and microcells as well as public and private systems in a DCCH environment, an HCS has been introduced between neighboring cells in IS-136. A DCCH-capable phone will be able to reselect a particular control-channel neighbor cell over another based on the type of relationship defined between the serving cell and a neighbor cell.

The HCS designations are used by a phone to assess the most suitable control channel on which to provide service, even if the signal strength of a neighbor is not the highest being received by the phone but is of a sufficient level to provide quality service.

#### 3.7.3.1 Preferred, regular, and nonpreferred cells

HCS enables the DCCH to identify and designate neighboring cells into three types: preferred, regular, and nonpreferred.

*3.7.3.1.1 Preferred* A preferred cell type has the highest preference. A hand-off (generated by the system) or reselection (generated by the phone) will be made to the preferred neighbor even if the signal strength received from the neighbor is lower than the serving cell. The main criteria here is that the preferred neighbor cell must have signal strength defined by the system designer as sufficient to provide quality service.

*3.7.3.1.2 Regular* A regular cell type has the second-highest preference. A hand-off or reselection will occur if the received signal strength of this neighbor is greater than the current serving cell signal strength plus a hysteresis value, and there is no eligible preferred cell.

*3.7.3.1.3 Nonpreferred* A nonpreferred cell type has the lowest preference. Hand-off and reselection will take place if the received signal strength of the serving cell drops below a certain threshold to provide service and if the signal strength of the neighbor is greater than the current cell plus a hysteresis. ACCs can also be specified in an HCS but the phone will, at that point, drop out of the DCCH environment. The hand-off and reselection criteria are explained mathematically in Appendix D.

It should be remembered that a cell type (either regular, preferred, or nonpreferred) is a relative attribute—a cell can be regular to one cell and preferred to others. This would be the case when two microcells are serving a WOS system and marked regular to each other. They may, however, be marked preferred to the surrounding macrocells, in which case each cell is considered regular by some neighbors but preferred (or even nonpreferred) by others.

### 3.7.3.2 Hierarchical cell structure example

Table 3.4 shows the neighbor-cell relationships that have been defined for the system and that will be broadcast on each cell to identify its neighbor cells. Each time the phone reselects a new DCCH, a new neighbor list is received that will tell the phone how to treat each of the new surrounding cells during reselection.

In Figure 3.28, using the broadcast neighbor information in Table 3.4, the phone camping on macrocell 1 would know that macrocell 2 was a regular neighbor and it would use the *regular neighbor cell* criteria when evaluating the received signal strength from macrocell 2. This would also mean that macrocell 2 would have to be of a greater signal strength, plus a hysteresis, to be considered a new control or traffic channel.

In comparison, the office microcell is marked as a preferred neighbor on the neighbor list broadcast from macrocell 1. If the signal strength received from the office microcell was above the predetermined *sufficient* threshold, a reselection or hand-off to that microcell would take

**Table 3.4**  
Neighbor-Cell Information

Cell	Neighbor-Cell Relationship
Macrocell 1	Macrocell 2 as a regular neighbor Office microcell as a preferred neighbor
Macrocell 2	Macrocell 1 as a regular neighbor Office microcell as a preferred neighbor
Office microcell	Macrocell 1 as a nonpreferred neighbor Macrocell 2 as a nonpreferred neighbor

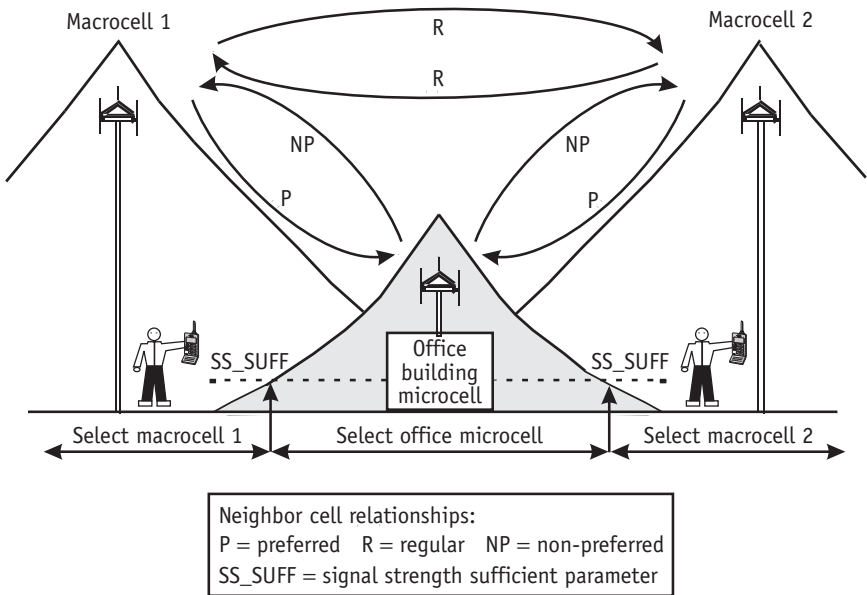

**Figure 3.28** Reselection based on HCS cell designation.

place—even if the signal strengths from the macrocells were greater. This threshold, called *SS\_SUFF*, is broadcast along with each neighbor. Appendix D describes *SS\_SUFF* in detail.

To complete the HCS example, consider the phone as being camped on the microcell. The neighbor list would indicate both macrocells as *nonpreferred*. As the phone leaves the microcell environment—assuming the phone to be traveling left to right—the signal strength from the microcell would decrease, and the signal from macrocell 2 would increase. Using the *nonpreferred* neighbor criteria, the following two criteria must be met:

- The signal strength from the microcell would have to drop below the sufficient signal-strength threshold before a reselection or hand-off to macrocell 2 could take place.
- The signal strength from macrocell 2 would have to be of a greater signal strength, plus a hysteresis, to be considered a new control or traffic channel.

This example demonstrates that HCS is a very powerful tool for RF engineers to use with a WOS or other application where traffic needs to be managed in a microcell environment.

### 3.7.3.3 Neighbor cell list

Each sector that supports a DCCH can broadcast information for as many as 24 neighbor cells. This information is used by the phone when evaluating each neighbor control channel in conjunction with the neighbors' signal strength. Neighbor cells from different hyperbands may be included. That is, 800-MHz control channels can reference 1,900-MHz neighbor cells and vice versa. This allows reselection between the frequency bands and the associated seamless service.

Note that a DCCH can broadcast information regarding analog control-channel neighbors as well as DCCH neighbors.

Table 3.5 shows a summary of the neighbor-cell list information that is broadcast for each DCCH neighbor cell. A more detailed description of the parameters can be found in the IS-136 specification.

The signal strength on neighbor channels will be measured at regular intervals defined by the broadcast parameter `SCAN_INTERVAL`. This parameter defines the number of hyperframes between signal-strength measurements.

**Table 3.5**  
Neighbor-Cell List Information

Parameter	Function
Channel number	RF channel number of that neighbor
Cell parameters	Network type (public, private, residential) Cell type (preferred, nonpreferred, or regular)
Cell hysteresis thresholds	IS-136 cell threshold and hysteresis parameters RSS_ACC_MIN, MS_ACC_PWR, RESEL_OFFSET, SS_SUFF, DELAY, HL_FREQ (see Appendix D)
PSID indicators	Optional information regarding private system identities
DVCC	Distinguish the channel from a cochannel

### 3.7.4 System registration

Registration is a function that gives a cellular system the ability to know the location and status of a cellular phone. Existing AMPS and TDMA registration schemes remain the same under IS-136, and several new forms of registration are introduced, providing for backward compatibility with existing registration schemes as well as enhanced tracking of phones' whereabouts.

For DCCH, registration messages are sent from the phone to the base station on the RACH. The registration-accept message is sent from the base station back to the phone on the ARCH.

Existing registration types maintained in IS-136 are listed as follows.

- Power-up;
- Periodic;
- Location area.

Additional types of registration supported in IS-136 are as follows.

- Power-down;
- New system registration (using SID/PSID);
- Change of control channel (from ACC/DCCH);
- Forced registration;
- User group registration;
- New hyperband;
- TMSI timeout;
- Deregistration;
- Location area using *virtual mobile location area* (VMLA).

#### 3.7.4.1 Power-Up registration

Power-up registration is used to inform the network that a subscriber is active when the phone is powered on, allowing the network to track the activity status of the phone.

#### 3.7.4.2 Power-down registration

Power-down registration is used to change the subscriber status from active to inactive as the phone is powered down. Phones marked inactive are not paged for call termination, thereby minimizing congestion. Power-down registration also makes it possible for the system to quickly determine when phones have powered down, enabling the system to initiate actions like call forwarding, voice mail, and recorded announcements, without having to wait for ringing time-out.

#### 3.7.4.3 Periodic registration

Periodic registration is used to help the network keep track of the phone throughout the system. It is used on both the ACC and on the DCCH. Periodic registration can either be based on a clock sent from the system or based on an internal clock in the phone. A phone sends a registration message to the system after a timer expires to keep the phone active in the system.

#### 3.7.4.4 New system registration (SID/PSID)

When a phone tuned to an ACC retrieves a registration ID message, it compares the current SID with its stored SID, that is, the SID corresponding to its latest-sent registration access. If the system area identities are different, a registration-access message is sent to the system.

The IS-136 specification supports the concept of private networks with a *private SID* (PSID). Phones tuned to a DCCH receive the list of private systems supported by a certain cell in the system-identity message and can register in an area served by a public/private network to which they subscribe. This registration takes place when a PSID stored in the phone matches the PSID of the public/private network broadcast on the DCCH. This registration enables a phone to keep the network informed about the system area in which it is operating. For example, the system can use this registration as a trigger to know that a phone has entered a wireless office service (WOS).

Figure 3.29 shows an example of SID and PSID change registration. The solid registration arrows indicate a change of SID registration where, like today, the phone recognizes that the SID from the new cell is different from the last cell. The dotted arrows entering the shaded area

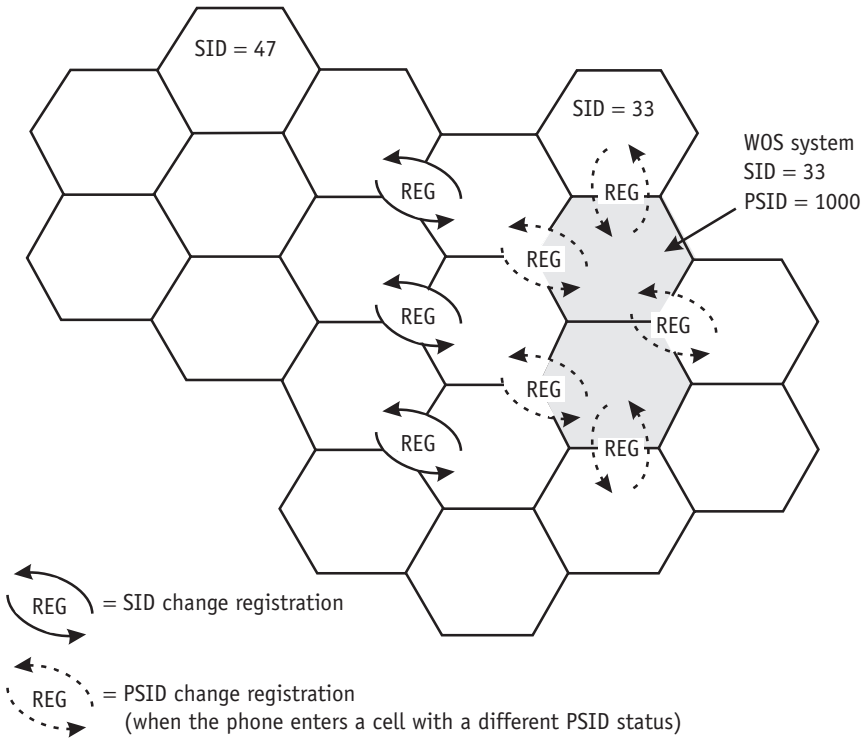

**Figure 3.29** Example of SID and PSID change registration.

represent registrations when a phone reselects into a cell that is broadcasting a PSID that the phone has stored in its memory (plus other associated identifiers). This registration would be performed by phones entering their WOS area. The dotted arrows leaving the shaded WOS represent the registration that a phone performs when it leaves an area that is broadcasting a different PSID or no PSID at all.

### 3.7.4.5 Change of control channel type registration

An IS-136 phone can access a system either on an ACC or a DCCH. A phone that had previously accessed an ACC, and that is now acquiring service on a DCCH, is required to perform a change of control channel type registration. The phone will also reregister when the ACC is reselected after service has been acquired on a DCCH. In this way, the system knows on which control channel to page the phone.

#### 3.7.4.6 Forced registration

It is also possible for the network to force phones to register. Forced registration allows systems to force a phone that is camping on a given DCCH to register on demand.

#### 3.7.4.7 User group registration

User groups can be defined for point-to-multipoint paging and registration.

#### 3.7.4.8 New hyperband

New-hyperband registration provides seamless phone operation between the 800-MHz and 1,900-MHz frequency bands for PCS services.

#### 3.7.4.9 TMSI timeout registration

TMSI timeout registration is used when a TMSI expires.

#### 3.7.4.10 Deregistration

Deregistration is a registration scheme through which a mobile notifies the system of its intent to leave its current network and reacquire service in a different type of network.

#### 3.7.4.11 Virtual mobile location area

VMLA is a registration scheme that allows individual registration areas to be defined. It is based on the concept of a phone being sent a list of *registration numbers* (RNUMs) upon initial registration. Each RNUM value is associated with one or more cells in such a way that the full RNUM list defines a domain of cells.

The phone will reregister when an unrecognized RNUM is encountered on a cell. This scheme can be applied on a per-phone basis and can more accurately track and control mobile registrations. Another benefit of VMLA-based registration is that it can be used to eliminate the ping-pong registration problem by dynamically centering each new registration area around the mobile. Figure 3.30 indicates a variable (RNUM) broadcast by a system on the BCCH channel.

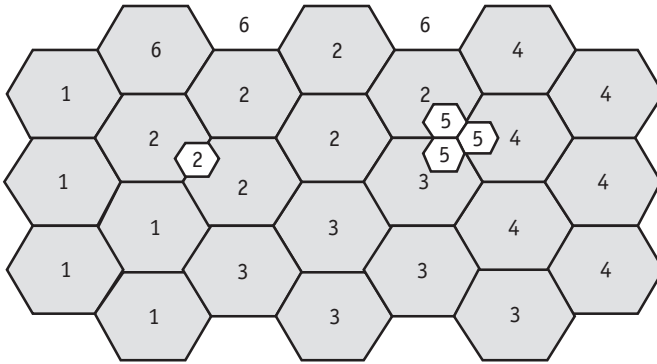

- The RNUM list is sent to phones at registration in a registration-accept message.
- Each cell broadcasts an RNUM.
- The phone will re-register if an unknown RNUM is received. This reduces problems involved with system border paging.

**Figure 3.30** Registration: VMLAs.

### 3.7.5 Mobile-assisted channel allocation (MACA)

A new function in IS-136 similar to MAHO is MACA. MACA is a process in which signal-strength reporting takes place while the mobile phone is monitoring a DCCH (camping). While monitoring the DCCH, the phone also measures signal strengths on specified frequencies and the signal quality of the current downlink DCCH. MACA signal-strength measurements can be used for quality-based frequency assignment of a DTC (with adaptive channel allocations) and reassignment of a DCCH if the DCCH is subject to severe interference. The base station, using the BCCH, sends a neighbor list informing the phone of where to look for potential cell reselection.

The mobile phone continuously reports MACA information to the base station to assist in determining the best channel. The mobile phone performs two MACA-related functions: *long-term MACA* (LTM) and *short-term MACA* (STM). LTM is a set of data containing the word error rate, bit error rate, and received signal strength for the current DCCH. STM contains received signal strength for the current DCCH and possibly for other channels. MACA reports are also sent back to the base station during other activities such as call origination, page message responses, and registrations.

### 3.7.6 Call processing

To make and receive calls, wireless phones must exchange information with the system prior to service. Additionally, the phone must perform other tasks such as handoff, authentication, and teleservice transportation.

#### 3.7.6.1 Origination

A call from a cellular phone begins with an access to the system on the control channel of the serving cell. The access includes an origination message containing the phone identification number (MIN), the serial number, and the called number. The system verifies the authenticity of the phone, the validity of the called number, and the availability of the network resources to handle the call prior to selecting an idle voice channel in the serving cell and ensures that adequate signal strength is received from the phone.

The voice channel can be analog or digital depending on the phone capability, preference, and channel availability. An IVCD message is then sent to the phone. This message, which can be repeated more than once, provides the phone with the selected voice channel to be used to complete the setup procedure.

Reorder, directed retry, and intercept messages are used to control situations that might have made the origination attempt fail.

#### 3.7.6.2 Paging

A call to a phone begins with a page message containing the phone identification number (MIN) being broadcast over all cells in the location area where the phone is expected to be.

When this message is recognized by the appropriate phone on an ACC, the phone tunes to the strongest control channel and returns a page response message as confirmation. The page response message returns the phone identification number and, if required, its ESN.

A phone camping on the DCCH does not have to retune to the strongest control channel, but it immediately responds to the page on the current RACH since a DCCH-capable phone is always monitoring the most appropriate control channel.

If the page response is valid and meets the signal strength criteria, and if the serial-number check is active and the returned and stored serial

numbers are found to be equal, then the system selects an idle analog voice or DTC in the cell identified by the page response. The voice channel is started and an initial voice-channel designation message is sent to the phone to complete the setup procedure. If no page response message is received within the paging period set by the switch, the page is considered unsuccessful.

### 3.7.6.3 Hand-off

IS-136 allows for hand-offs between any combination of analog voice channels and DTCs at 800 MHz, and DTCs between the 800-MHz and 1,900-MHz frequency band. The HCS algorithms may be taken into account in the hand-off process to provide coherent control and voice-channel borders within the system.

### 3.7.6.4 Call release

At call release, a phone is informed of the DCCH's location for its current serving cell. This message enables a phone to return to a serving DCCH directly after a call without having to rescan for a DCCH. The message is sent to DCCH-capable phones on call completion from an analog voice channel and DTC.

## 3.7.7 Authentication and privacy

The authentication process uses messaging on the DTCs, the DCCH, and analog voice or control channels to convey authentication information. This is used to validate a phone on the system. Authentication is a vital tool to inhibit cloning, in which a counterfeit phone takes on the identity of a normal phone for the purposes of fraudulent activity.

### 3.7.7.1 Message encryption

To protect sensitive subscriber information, and to enhance the authentication process, IS-136 supports encipherment of a select subset of signaling messages (those that contain the sensitive information).

### 3.7.7.2 Voice privacy

IS-136 provides a degree of cryptographic protection against eavesdropping in the phone-base station segment of the connection. Requests to

activate/deactivate the voice privacy feature may be made during the call setup process, or when the phone is in the conversation state.

### 3.7.7.3 Enhanced privacy and encryption

The next revision of IS-136 will introduce an enhanced voice privacy feature, signaling message encryption and user data encryption increasing the degree of cryptographic protection.

### 3.7.8 Teleservice transport

IS-136 provides a mechanism for the transport of teleservice information between a teleservice server/message center in the network, and the phone. As well as standard teleservices such as CMT, OATS, OAP, and GUTS, IS-136 allows carrier-specific teleservices to support other non-standardized services.

Regardless of the teleservice being transported, IS-136 uses the R-data packets to send and receive the information. Corresponding acknowledgment packets are used to indicate the success of the delivery.

Teleservice messaging is not limited to network-originated messages. Mobile-originated teleservices provide a similar transport mechanism but from the phone or wireless device in a DCCH environment.

Future IS-136 revisions will also support a *segmentation and reassembly* (SAR) function, which will allow longer teleservice messages to be communicated by splitting the message into manageable units prior to transmission and joining them together again at the receiver.

#### 3.7.8.1 Teleservice point-to-point delivery and acknowledgment

Figure 3.31 depicts the point-to-point delivery and acknowledgment process between the base station and the phone. The phone receives notification of a pending teleservice message (a SPACH notification) and responds with a SPACH confirmation (similar to a page and page response for voice calls). The system then begins delivery of the teleservice message that was received from the message center/teleservice server. At the end of the message delivery across the air interface, the phone sends back an accept or reject message to indicate success or failure of the message delivery.

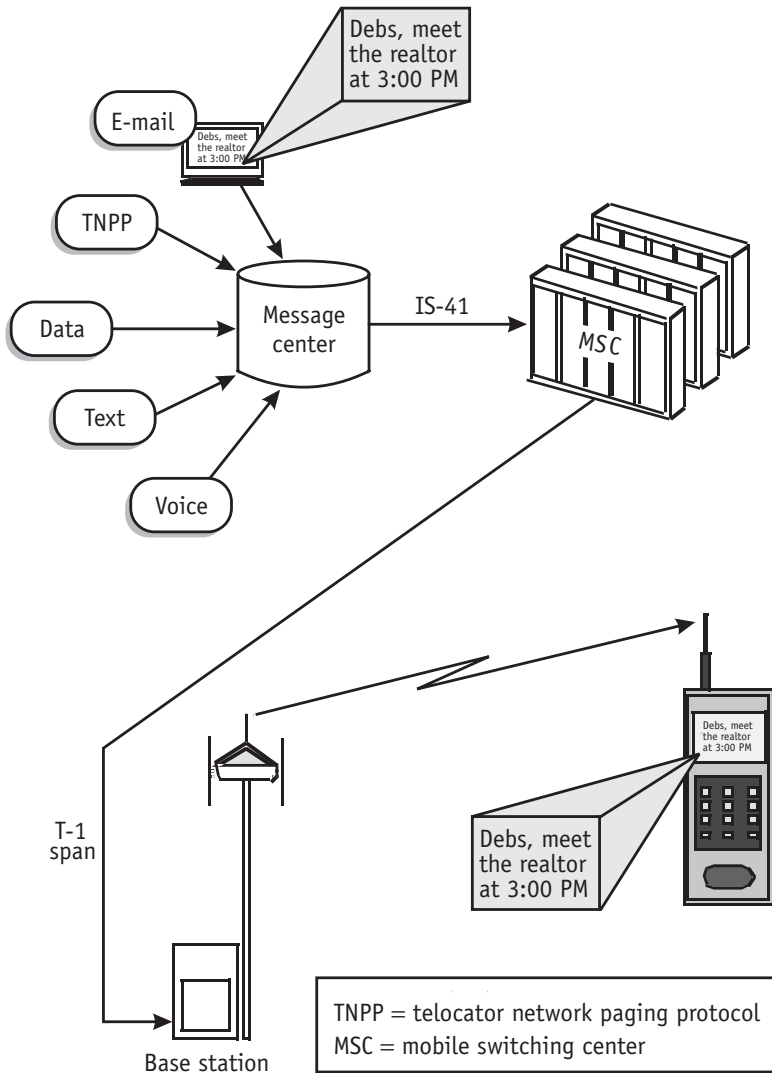

**Figure 3.31** Teleservice point-to-point delivery and acknowledgment.

Each message can be acknowledged at various stages during transfer to ensure the successful delivery of over-the-air interface messages. This process includes SPACH layer-2 ARQ, layer-3 R-data accept-or-reject messages, and teleservice specific delivery and manual acknowledgments.

### 3.7.8.2 Teleservice delivery on the digital traffic channel

Point-to-point teleservice messages may also be delivered over the DTC using FACCH messaging. The same features and functionality of DCCH-delivered messaging are therefore included to provide a means of sending teleservice information during a voice call.

## 3.8 Identity structure

Private system identities, cell identities, and new *system operator codes* (SOCs) have been introduced to support the new features and capabilities on the DCCH. The IS-136 system allows for several different types of phone identities. The traditional use of 10-digit directory numbers as a means of uniquely referencing mobile phones has been augmented to provide increased paging capacity, thereby allowing for full international roaming while remaining backward-compatible with today's phone identity strategy.

### 3.8.1 Mobile phone identities

There are four key methods for identifying a phone.

#### 3.8.1.1 Temporary mobile station identity

A TMSI is a 20- or 24-bit number representing a temporary mobile identity that is assigned to a phone by the system at initial registration. This shortened identifier provides enhanced paging capacity on the air interface, since a single page of messages can reference more 20-bit TMSIs than 34-bit MINs and, thus, page more phones at a time.

**Table 3.6**  
SID Structures: Network Types

Network Type	Value
Public	1XX
Private	X1X
Residential	XX1

### 3.8.1.2 International mobile station identity (IMSI)

An IMSI is an internationally unique number developed to facilitate seamless roaming in future global mobile networks. Its length is 50 bits.

### 3.8.1.3 Mobile identification number (MIN)

Today's MIN is a 34-bit number. It continues to serve as the initial MSID, enabling the current networking and authentication mechanisms to coexist with the DCCH.

### 3.8.1.4 Electronic serial number (ESN)

The ESN is an 11-digit serial number that is unique to a mobile phone.

## 3.8.2 System identity structures

New methods of identifying IS-136 systems have been introduced to support enhanced features such as private systems.

### 3.8.2.1 System identity (SID)

The SID has the same meaning in IS-136 as in an AMPS system and represents an international identification and a system number identifying the service area and frequency band (A or B 800 MHz, A through F 1,900 MHz).

### 3.8.2.2 Network types

A new SID structure has been introduced to allow cellular phones to distinguish between public, private, semiprivate, and residential (personal) base stations (see Table 3.6). These new network types allow phones to behave differently according to the type of system providing service to the user. For example, phones only requiring plain old cellular service need not reselect or camp on cells marked private, thereby improving their time to service. Also, phones requiring service on a residential system might perform different scanning routines in order to find their home system. The network type is represented by a 3-bit field on the DCCH structure and by neighbor-cell messages on the broadcast DCCH.

A DCCH might take on the identity of several network types at the same time since X represents the do not care setting. This is useful when a public macrocell is also used to provide a private WOS to a customer. In

this case, the cell would be classed as semiprivate. In the DCCH environment, cells can also be defined within several categories of network types, including the following:

- *Public*: Cells that provide the same basic service to all customers;
- *Semiprivate*: Cells that provide the same basic service to all customers and provide special services to a predefined group of private customers. This type would be used in the case of a cell providing service to a WOS system as well as to public users.
- *Private*: Cells that provide special services to a predefined group of private or WOS customers only and that do not support public use of that cell.
- *Semiresidential*: Cells that provide the same basic service to all customers and special services to a predefined group of residential customers. This type would be used in a neighborhood where the public macrocell was also providing residential cellular service.
- *Residential*: Cells that provide special services to a predefined group of residential customers only and that do not support public use of the cell. The *personal base station* (PBS) would be classed as a residential system.
- *Autonomous*: Cells that broadcast a DCCH in the same geographical area to other DCCH systems but that are not listed as a neighbor on the neighbor list of the public system. Examples of autonomous systems would be the personal base station (PBS) or private microcell systems that are not frequency-coordinated with the public system. These cells require the phones to perform special frequency-scanning algorithms in order to find them.

### 3.8.2.3 System operator code (SOC) and base station manufacturer code (BSMC)

The SOC and the BSMC are new system identities that enable a phone to recognize base stations either belonging to a certain cellular operator (SOC) or supplied by a specific manufacturer (BSMC). In addition to

system recognition, these identities enable a phone to activate proprietary signaling protocols to provide advanced services that might not be available from other carriers or equipment manufacturers. IS-136 defines the SOC and BSMC assignments.

#### 3.8.2.4 Mobile country code (MCC)

A *mobile country code* (MCC) is included in system broadcast information to identify the country in which the system is operating. This supports international applications of IS-136 and international roaming.

#### 3.8.2.5 Private system identity (PSID)

A PSID is assigned to a specific private system by the operator to identify that system to phones in the coverage area of that system. PSIDs can be assigned on a sector-by-sector basis that allows very small service areas to be defined. Alternatively, many cells, as well as systems, could broadcast by the same PSID to create a geographically large virtual private system. Phones that recognize PSIDs will notify the system and display a specific system name on the screen to inform the user that they have entered the private system.

A single DCCH can broadcast up to sixteen PSIDs, allowing the support of up to sixteen different virtual private systems on one DCCH. This feature would be useful in a technology park or campus where it would not be economical to support a DCCH for each small customer requiring WOS features. Figure 3.32 shows a typical private system configuration.

It is important to note that a default system banner or alpha tag of the public system is displayed when the phone is not near the location of its private system. This is shown in Figure 3.32. The phone is looking for a PSID of 9927 (Mountain High Ski Resort) but that PSID is not broadcast for this cell. In this case, the phone would display the default alphanumeric SID of the public system, as shown in Figure 3.32.

**3.8.2.5.1 PSID Ranges** There are over 65,000 different PSIDs split into four ranges, with each range having unique properties described in the following sections.

*Range 1.* Range 1 is reserved for SID-specific PSIDs, that is, PSIDs that will be meaningful in only one service area. An example is a small business WOS system that is contained in one or more sites under a single SID

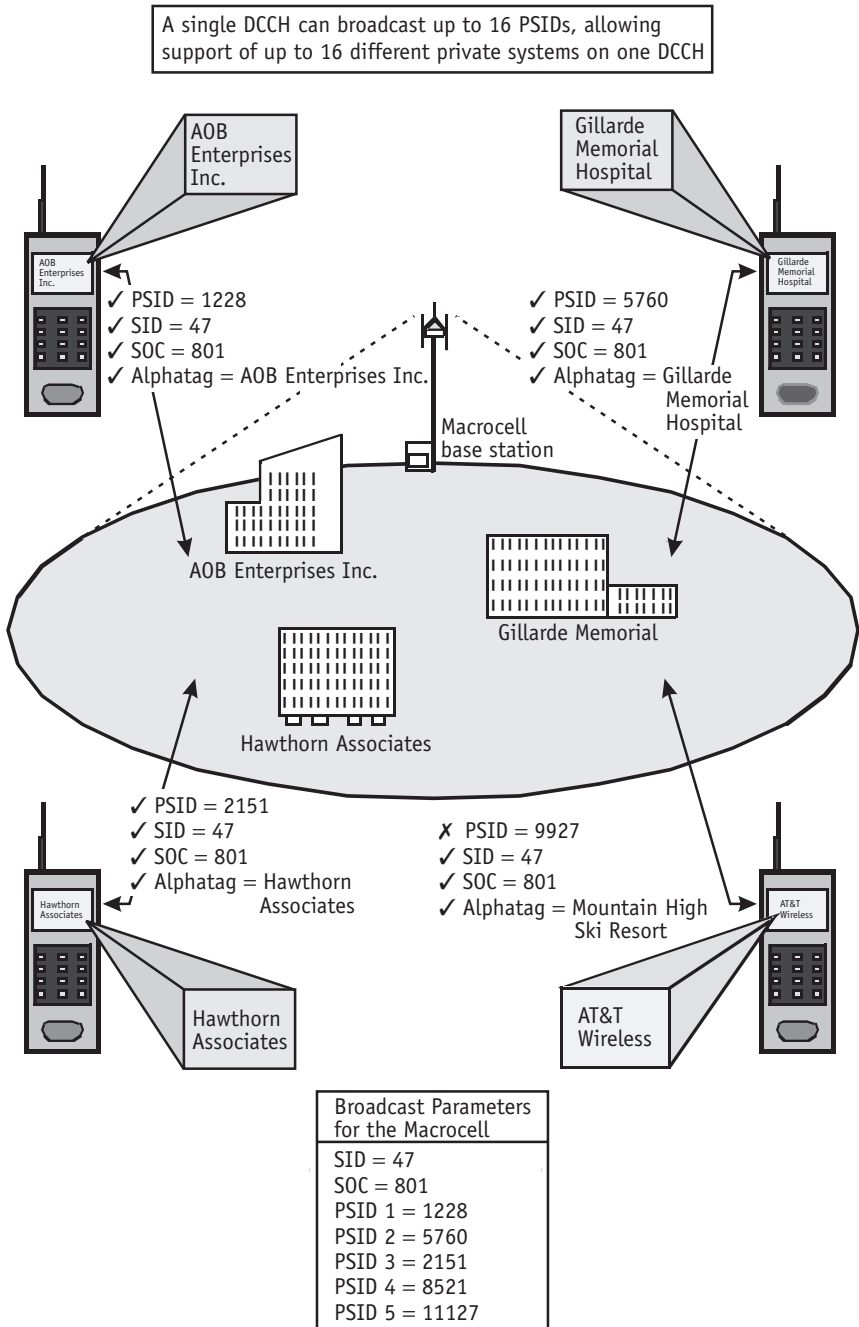

Figure 3.32 Private system configuration.

service area, although it does not cover multiple cities. Reasons for using Range 1 include the following.

- The PSIDs are wholly dependent on the SID.
- No intermarket negotiation needs to take place to allocate PSIDs in this range.
- The PSIDs in this range can be safely reused in any market that has a different SID.

*Range 2.* Range 2 has significance for PSIDs related to national accounts served by a single cellular carrier. These PSIDs are independent of the SID and have meaning across all markets broadcasting the same SOC. These PSIDs would be used for large national accounts with customers who roam all over the country. This designation would allow the phones to be programmed in one home market for use in multiple cities.

*Range 3.* Range 3 takes the PSID designation one step further and provides a range in which PSIDs are relevant on a nationwide basis. For example, a national account receiving service from multiple cellular carriers would use the same PSID for all cellular service provided. The PSID defined in this range would have to be standardized on an intercarrier basis but would allow large national customers to receive seamless private-system service from multiple carriers.

*Range 4.* Range 4 provides a PSID range that is globally unique. This range would be used for international roamers.

#### 3.8.2.6 Residential system identity (RSID)

In a manner similar to PSIDs, *residential SIDs* (RSIDs) identify residential systems within the public cellular coverage. RSIDs can be used to create residential-service areas or neighborhood residential systems by broadcasting an identifier that is recognized by phones as being at home and, therefore, receiving special services (such as billing). A primary use of RSIDs is in the PBS, which allows a cellular phone to be used like a cordless phone in conjunction with a residential cellular base station. RSIDs can also be broadcast on the macrocellular system to create virtual residential networks.